



# Viatran

## Model: AT-1000

### L.P.G. FREEZE VALVE

P/N: 2156006200



199 Fire Tower Drive  
Tonawanda, NY 14150  
Phone: 716-629-3802  
Fax: 716-693-9162  
solutions@viatran.com  
[www.viatran.com](http://www.viatran.com)



VIATRAN Model AT-1000  
L.P.G. FREEZE VALVE

## **OPERATION AND MAINTENANCE INSTRUCTIONS**

### **GENERAL INFORMATION**

The VIATRAN AT-1000 LPG Freeze Valve was developed and calibrated to establish the presence or absence of moisture in propane type liquefied petroleum gases by the Valve Freeze Method. The Valve Freeze Method was published for information only by the American Society for Testing Materials in the "ASTM 1963 Standards-Volume 18". The use of this valve and test method provides a relative measure of the tendency of propane type liquefied petroleum gases containing moisture to freeze in pressure reducing regulators and thereby interrupt the normal flow of gas. The test method is applicable to all propane type LP gases including those that contain certain anti-freeze agents.

A liquid-phase sample is allowed to flow through the valve under the full flow condition to chill the valve housing by the cooling effect of the change from a liquid to the gaseous state. After the housing has been chilled, the opening of the valve is switched to the testing condition and the time required for the freezing moisture to close the valve opening is measured. This time is recorded as the freeze time of the sample. If the freeze time indicates that the product may cause freezing of pressure reducing regulators, an anti-freeze agent may then be added, if desired.

The valve and test method are particularly suited for use outside the laboratory. Therefore, they may be used by non laboratory personnel and under existing conditions at commercial terminals with sufficient accuracy to determine if the moisture content of the product meets specifications.

### **FUNCTIONAL DESCRIPTION**

1. The freeze valve has two operating positions, a full flow position for chilling and/or purging and a restricted flow position for testing.
2. A spring-loaded valve stem and cam action actuator provide instantaneous switching from the full flow condition to the testing condition.
3. The valve features includes four (4) independent restricted flow passages acting as flow smoothers to maintain a pressure drop which will result in increased expansion of the fluids and increased cooling effect when entering the testing zone.
4. The valve incorporates a filter to exclude foreign particles from the testing zone.
5. The outlet of the valve has internal threads to assist the operator in determining when the flow has been interrupted or shut off as a result of ice having formed in the aperture of the valve. The instant the LP gas stops flowing over the threads, a frost line rolls over the lip of the valve outlet.

# VIATRAN Model AT-1000

## L.P.G. FREEZE VALVE

### INSTALLATION

The sensitivity of the moisture test measurements is such that all tests should be performed with freeze valve apparatus connected to the bulk supply source. If this is not possible, a sample may be taken into a sample cylinder having a minimum capacity of three gallons. The sample should be collected in accordance with directions given in the ASTM Method D1265, Sampling Liquid Petroleum (LP) Gases or in NGPA Publication 2140. In no case shall the sample pressure be over 100 pounds per square inch in excess of the vapor pressure of the product at the sampling temperature.

For proper assembly the valve should be connected to the bulk supply source in a horizontal position with the valve outlet in the most advantageous position for visual observation to assist the operator during the measurements.

NOTE: Connect the freeze valve to the sample source with a clean pipe or metal tubing.  
**DO NOT USE RUBBER HOSE OR PLASTIC LINED HOSE.**

NOTE: The freeze valve has no full off condition. Therefore:  
**A SHUTOFF VALVE SHOULD BE USED INSTALLED IN THE SYSTEM BETWEEN THE BULK SUPPLY AND THE FREEZE VALVE.**

NOTE: Remove and save the protective hex set screw (Item # 28 of valve assy) on the valve body which protects the outlet of the valve, before any measurements are attempted. With the set screw removed, full-open valve condition will allow free flow for the ASTM test. Remember to replace the set screw to protect the orifice from debris.

### OPERATING INSTRUCTIONS

1. After the valve apparatus has been connected to the LP gas source, open the valve between the main source and the freeze valve and move the valve actuator to the purge position (actuator parallel to the valve body).



1. Valve actuator in purge position

2. Purge the sample line and valve for approximately 30 seconds, then switch the valve actuator to the test position (actuator perpendicular to the valve body) for 2 or 3 seconds, then back to purge position for 2 or 3 seconds, and back to the test position for 2 or 3 seconds.



2. Valve actuator in test position

3. Continue the intermittent test/purge/test/purge until valve housing around the valve outlet is uniformly covered with frost.

# VIATRAN Model AT-1000

## L.P.G. FREEZE VALVE

4. Immediately snap the valve actuator to the test position and simultaneously start a stop watch. Stop the watch the instant the LP ceases to flow from the valve outlet due to ice forming in the aperture (aka freeze-off). This is indicated when a frost line rolls over the lip of the valve outlet.



3. Valve outlet with protective screw removed

5. DISREGARD THE TIME FOR THE FIRST TEST. Immediately wipe threads of the valve outlet with a clean dry cloth and move the valve actuator to the purge position to remove any ice from the testing orifice. **NOTE:** Failure to purge the valve 15 to 20 seconds between tests to remove all ice will result in inaccurate freeze time measurements.
6. Repeat the test procedure to obtain three (3) successive tests results which give consistent freeze-off times to within +/- 5 seconds.
7. In accordance with ASTM standards, pass and fail criteria are as follows:  
Freeze-off < 60 seconds = failed test due to excessive moisture content  
No freeze-off  $\geq$  60 seconds = passed test, dryness meets or exceeds ASTM D2713-13 standard
8. When the freeze valve is operated under calibration conditions on a product containing no antifreeze agent, a three test average freeze-off time of 24 seconds is approximately equivalent to the initial color change of the indicator in the NGPA Cobalt Bromide Test method. (See NGPA Publication 2140).
9. When the product being tested contains an anti-freeze agent, freeze-off times can not accurately measure the moisture content of the product.

## MAINTENANCE

Drawing #AT1000 (page 6) should be referenced for the following:

The screen (Item No. 9) covering the Inlet of the connection nipple (Item No. 8) and the filter element (Item No. 14) should be cleaned at regular intervals determined by the service hours of the valve. It is recommended that they be washed in petroleum ether or mineral spirits and dried with clean dry air or nitrogen. Avoid contamination with dirt or grease while handling the filter element.

If the valve is dropped or damaged in any manner, it should be returned to VIATRAN for reconditioning and recalibration.

The freeze valve is packed in a polyurethane-lined case. The case is of high-impact material to help prevent damage to the valve.

VIATRAN Model AT-1000  
L.P.G. FREEZE VALVE

**PARTS LIST**

The following table names and describes the maintenance parts of the Model AT-1000 LPG Freeze Valve. All parts are listed by Item number and commercial description (see page 6).

ITEM	NAME AND DESCRIPTION	PART NO.
Complete assy.	LPG Freeze Valve	2156006200
7	Filter Body	3599604893
8	Connection Nipple	3599604894
10	Connection Nut	3599604895
11	Plug	3599604896
12	Gasket	3551030820
Service Kit	Service Kit – Consists of Screen, Gasket, Compression Spring, Filter Element w/Gasket, Internal Retaining Ring, Housing O-Ring, & Set Screw	35FVSRVKIT

**SPECIFICATIONS.....AT-1000 L.P.G.FREEZE VALVE**

SIZE 8" long x 1" diameter -- 203.2 mm long x 25.4 mm diameter

WEIGHT 1 pound-2 ounces -- 510.3 grams

CONNECTION .880-14 NGO left-hand external threads

MATERIAL Stainless Steel

OPERATING PRESSURE Less than 100 pounds/in<sup>2</sup> (7.03 Kg/cm<sup>2</sup> g) plus vapor pressure of product at test temperature

STANDARDS ASTM D 2713-75 -- JLPGA-S-10T-7B

CE Conformity: Complies with PED2014/68/EU

# AT-1000 Freeze Valve Assembly

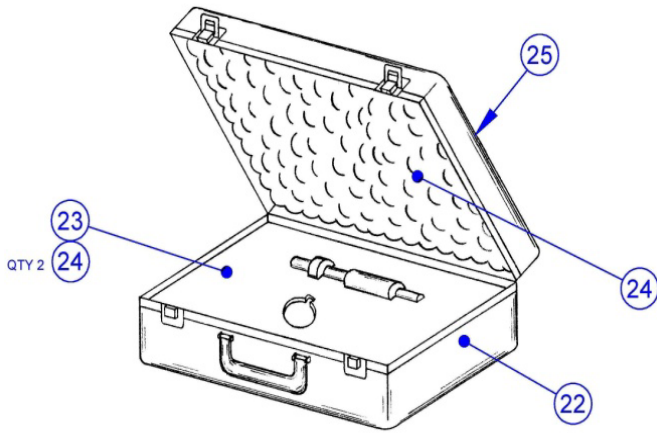
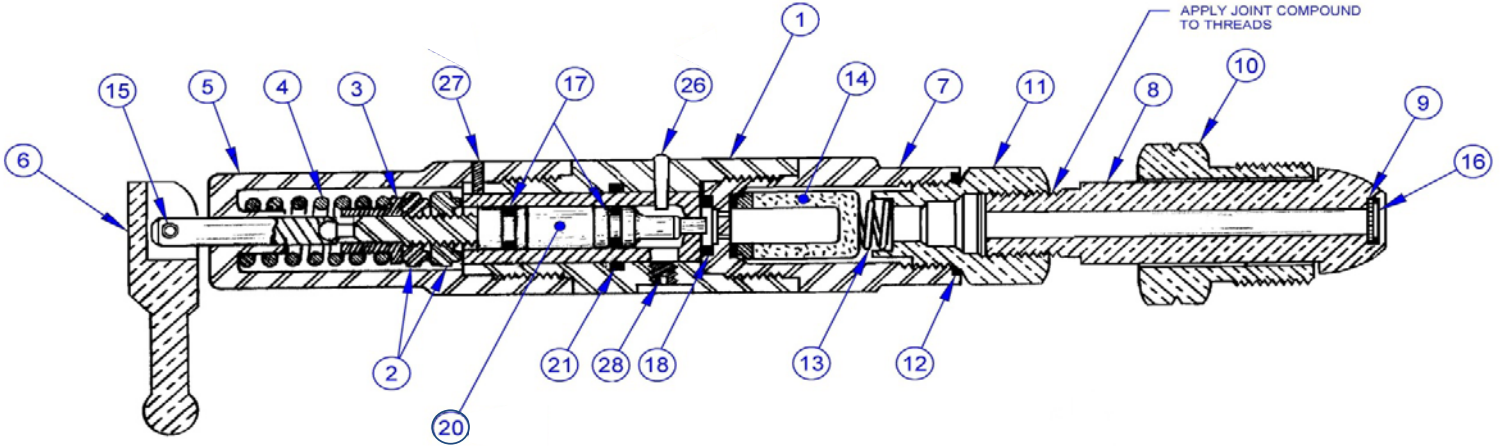

**CASE ASSEMBLY**  
P/N: 2156006100

P/N: 2156006100			
ITEM	PART NO.	DESCRIPTION	QTY
		MODEL LABEL	1
		FOAM INSERT, GREY	3
		FOAM INSERT, DIE CUT	1
		CASE, BLACK	1

P/N: 2156006200			
ITEM	PART NO.	DESCRIPTION	QTY
28	SEE SERVICE KIT	SHSS ¼-20 X ¼ LG	1
27		BRASS PIN 1/16 DIA	3/16"
26		T TAPER PIN 5/0 X 3/8 LG	1
25	SEE BILL OF MATERIAL FOR CASE ASSEMBLY P/N: 2156006100		
24			
23			
22			
21		O-RING, #2-014 COMP N103-7	1
20		STEM & BODY ASSEMBLY	1
19			
18	SEE SERVICE KIT	O-RING, #2-011 COMP N103-7	1
17		O-RING, #2-008 COMP N103-7	2
16	SEE SERVICE KIT	RETAINING RING	1
15	3599674476	ROLL PIN, 3/32 X ½"LG, SST	1
14	SEE SERVICE KIT	FILTER ELEMENT	1
13	SEE SERVICE KIT	COMPRESSION SPRING	1
12	SEE SERVICE KIT	GASKET	1
11	3599604896	PLUG	1
10	3599604895	CONNECTION NUT	1
9	SEE SERVICE KIT	SCREEN	1
8	3599604894	NIPPLE	1
7	3599604893	FILTER BODY	1
6	3599602388	ACTUATOR	1
5		SPRING HOUSING	1
4		COMPRESSION SPRING	1
3		SPRING GUIDE	1
2		ADJUSTING NUT	2
1		VALVE HOUSING	1
	35FVSRVKIT	SERVICE KIT INCLUDES ITEMS 9, 12, 13, 14, 16, 18 & 28	1
ITEM	PART NO.	DESCRIPTION	QTY

**NOTE:** Only customer serviceable P/N's are listed.