

PD6800-0L1 Explosion-Proof Loop-Powered Process Meter with Bargraph

Instruction Manual



- Fully-Approved Explosion-Proof Loop-Powered Meter
- 4-20 mA Input with $\pm 0.03\%$ Accuracy
- 3.0 Volt Drop (6.0 Volt Drop with Backlight)
- Easy Field Scaling in Engineering Units without Applying an Input
- 0.6" (15.2 mm) 5 Digits Main Display
- 0.4" (10.2 mm) 7 Alphanumeric Characters Secondary Display
- Display Mountable at 0°, 90°, 180°, & 270°
- SafeTouch Through-Glass Button Programming
- Display Input in Two Different Scales Simultaneously - Great for Level Applications
- 20-Segment Level Indicator Bargraph
- Open Collector Output Assignable to High or Low Alarm
- HART® Protocol Transparent
- Loop or External DC-Powered Backlight Standard
- Operating Temperature Range: -40 to 75°C (-40 to 167°F)
- Installation Temperature Range: -55 to 75°C (-67 to 167°F)
- CSA Certified as Explosion-Proof / Dust-Ignition-Proof / Flame-Proof
- ATEX and IECEx Certified as Explosion-Proof
- Conformal Coated PCBs for Dust and Humidity Protection
- Password Protection
- 32-Point Linearization
- Wide Viewing Angle
- Built-In Flange for Wall or Pipe Mounting
- Explosion-Proof, IP68, NEMA 4X Die-Cast Aluminum & Stainless Steel Enclosures
- Two 3/4" NPT or M20 Conduit Openings
- 2" U-Bolt Kit Available
- 3-Year Warranty

PRECISION DIGITAL CORPORATION

233 South Street • Hopkinton MA 01748 USA
Tel (800) 343-1001 • (508) 655-7300

www.prediq.com

PRECISION
DIGITAL

Disclaimer

The information contained in this document is subject to change without notice. Precision Digital Corporation makes no representations or warranties with respect to the contents hereof; and specifically disclaims any implied warranties of merchantability or fitness for a particular purpose.

CAUTION

- Read complete instructions prior to installation and operation of the meter.

WARNINGS

- Risk of electric shock or personal injury.
- This product is not recommended for life support applications or applications where malfunctioning could result in personal injury or property loss. Anyone using this product for such applications does so at his/her own risk. Precision Digital Corporation shall not be held liable for damages resulting from such improper use.
- Failure to follow installation guidelines could result in death or serious injury. Make sure only qualified personnel perform the installation.
- Never remove the meter cover in explosive environments when the circuit is live.
- Cover must be fully engaged to meet flame-proof/explosion-proof requirements.

WARNING

Cancer and Reproductive Harm - www.P65Warnings.ca.gov

Limited Warranty

Precision Digital Corporation warrants this product against defects in material or workmanship for the specified period under "Specifications" from the date of shipment from the factory. Precision Digital's liability under this limited warranty shall not exceed the purchase value, repair, or replacement of the defective unit. See Warranty Information and Terms & Conditions on www.predig.com for complete details.

© 2023 Precision Digital Corporation.
All rights reserved.

Introduction

The PD6800-0L1 is a rugged, full-featured, explosion-proof loop-powered meter ideal for demanding applications in hazardous areas or in the harshest environmental conditions. The product is CSA Certified as Explosion-Proof, Dust-Ignition-Proof, and Flame-Proof, and ATEX & IECEx Certified as Explosion-Proof. It is available in either an aluminum or stainless steel enclosure with ¾" or M20 conduit connections. It will operate down to -40°C and is approved for installation in areas where the temperature gets as cold as -55°C, however the display will cease functioning.

The meter derives all of its power from the 4-20 mA loop, thus making installation a simple matter of wiring the instrument into the existing loop. No external power is required. Programming is performed using the four SafeTouch through-glass buttons and can be done without removing the cover. In addition, the meter can be scaled with or without a calibration signal.

The backlit LCD display consists of two lines and a bargraph. The main line of the display has five full digits and is used to display the process variable. The secondary line has seven alphanumeric characters and is used for a tag, engineering units, or displaying the input in different units. For instance, the top line could display the height of the tank in feet and the bottom line could display the same input in gallons. The bargraph provides a quick visual of the current state of the process variable. The backlight makes the display visible under any lighting condition and can be powered from either the 4-20 mA loop or from a separate DC power supply.

Ordering Information

Aluminum Enclosure

| Model | Description |
|----------------|---|
| PD6800-0L1 | Explosion-Proof Loop-Powered Process Meter with Backlight and Two 3/4" Conduit Openings |
| PD6800-0L1-M20 | Explosion-Proof Loop-Powered Process Meter with Backlight and Two M20 Conduit Openings |

Stainless Steel Enclosure

| Model | Description |
|-------------------|---|
| PD6800-0L1-SS | Explosion-Proof Loop-Powered Process Meter with Backlight and Two 3/4" Conduit Openings |
| PD6800-0L1-SS-M20 | Explosion-Proof Loop-Powered Process Meter with Backlight and Two M20 Conduit Openings |

Accessories

| Model | Description |
|-------------------------------------|--|
| PDAPLUG75 | 3/4" NPT 316 Stainless Steel Conduit Plug with Approvals |
| PDAPLUGM20 | M20 316 Stainless Steel Conduit Plug with Approvals |
| PDAREDUCER-75M-M20F | M-3/4" NPT to F-M20 Reducer with Approvals |
| PDAREDUCER-75M-50F | M-3/4" NPT to F-1/2" NPT Reducer with Approvals |
| PD9501 | Multi-Function Calibrator |
| PD9502 | Low-Cost Signal Generator |
| PDA1001 | USB Power Bank |
| PDA1002 | 6" DIN Rail Mounting Kit |
| PDA1024-01 | 24 VDC Power Supply for DIN Rail |
| PDA-SSTAG | Custom Stainless Steel Tag (see website for convenient ordering form) |
| PDA6846-SS | Stainless Steel 2" U-Bolt Kit. All Material: Stainless Steel; (1) U-Bolt for 2" Pipe with (2 each) Washers, Lock Washers, and Nuts |

Note: Unless otherwise specified, the above accessories do not carry hazardous area approvals and are thus not suitable for location in hazardous areas.

Table of Contents

| | |
|--|----|
| Introduction..... | 2 |
| Ordering Information..... | 3 |
| Specifications | 6 |
| General | 9 |
| Input | 9 |
| Open Collector Output | 9 |
| Enclosure | 10 |
| General Compliance Information | 11 |
| Electromagnetic Compatibility..... | 11 |
| Product Ratings and Approvals..... | 11 |
| EU Declaration of Conformity | 12 |
| Safety Information | 12 |
| Installation | 12 |
| Unpacking | 12 |
| Cover Jam Screw | 12 |
| Mounting | 12 |
| Dimensions | 13 |
| Connections | 14 |
| Wiring Diagrams | 15 |
| External Acknowledge Connection | 15 |
| Open Collector Output Connections | 15 |
| Setup and Programming | 16 |
| Overview | 16 |
| SafeTouch Buttons | 16 |
| SafeTouch Button Operation..... | 16 |
| SafeTouch Button Tips and Troubleshooting | 16 |
| Buttons and Display | 17 |
| Main Menu Display Functions & Messages | 18 |
| Main Menu | 18 |
| Setting Up the Meter (SETUP) | 19 |
| Setting Numeric Values | 19 |
| Setting the Level Decimal Point (DECIMAL) | 19 |
| Scaling the Meter (SCALE)..... | 20 |
| Minimum Input Span..... | 20 |
| Scale Error Message (SPN ERR) | 20 |
| Scaling the Tank Level Indicator (PERCENT)..... | 20 |
| Configuring the Display (DISPLAY)..... | 20 |
| Setting the Tag (TAG)..... | 21 |
| Setting Up the Password (PASSWORD) | 21 |
| Locking the Meter | 21 |
| Making Changes to a Password Protected Meter | 21 |
| Disabling Password Protection | 21 |
| Advanced Features Menu (ADVANCE) | 22 |
| Advanced Features Menu & Display Messages..... | 23 |
| Alarm Output (OUTPUT)..... | 24 |
| Input Signal Filter (FILTER)..... | 24 |
| Volume Display Scaling (VOLSCALE) | 24 |
| Level Input Live Signal Calibration (LVL CAL)..... | 25 |
| Internal Calibration (ICAL)..... | 25 |
| Calibration Error Message (SPN ERR) | 25 |
| Level Input Multipoint Linearization (MULTIPT)..... | 25 |
| Information (INFO)..... | 25 |
| Operation | 26 |
| Front Panel Buttons Operation | 26 |
| Display Maximum, Minimum, and Input Current | 26 |
| Reset Meter to Factory Defaults | 26 |
| Factory Defaults & User Settings | 27 |
| Troubleshooting | 27 |
| Troubleshooting Tips | 27 |
| Quick User Interface Reference | 28 |

Table of Figures

| | |
|--|----|
| Figure 1. Enclosure Dimensions - Front View..... | 13 |
| Figure 2. Enclosure Dimensions - Side View | 13 |
| Figure 3. Enclosure Dimensions - Top View | 13 |
| Figure 4. Connector Board | 14 |
| Figure 5. Connections without Backlight | 15 |
| Figure 6. Connections with Loop-Powered Backlight..... | 15 |
| Figure 7. Connections with Externally-Powered Backlight..... | 15 |
| Figure 8. External Alarm Reset/Acknowledge Connections | 15 |
| Figure 9. Connection to Device with Internal Pull-Up | 15 |
| Figure 10. Output Connections | 15 |

Physical Features



The ProtEX-Pro PD6800L-0K0 comes with two 3/4" NPT conduit openings and the PD6800L-0K0-M20 comes with two M20 conduit openings.

Great for Cold Temperatures

The ProtEX-Pro PD6800L will operate over a temperature range of -40 to 75°C (-40 to 167°F). Below -40°C, the display will cease functioning, however, the instrument is approved to be installed in locations where the temperature goes down to -55°C.



Wide Viewing Angle

The window and display module have been optimized to provide a wide viewing angle of approximately ±40°; nearly twice that of the competition.



Easy Pipe Mounting

The ProtEX-Pro comes with a built-in mounting flange. This allows for easy mounting to walls or pipes using the [PDA6846-SS](#) Stainless Steel 2" U-Bolt Kit. A slot on the back of the enclosure makes it easy to center the unit on a pipe.



Tamper-Proof Capability

The instrument can be made tamper-proof by inserting a wire through the built-in loop on the base of the enclosure and a hole in the lid of the enclosure and securing this wire with a lead seal.



Rotatable Display Module

The display module can be rotated in 90° increments providing added mounting flexibility. Plus the various conduit connections allow a variety of installation options.



Stainless Steel Tag Attaching Loop

The enclosure is equipped with a loop at the top to easily attach a [PDA-SSTAG](#) stainless steel tag.



Accessories

PDA1024-01 24 VDC Power Supply



The [PDA1024-01](#) is a DIN rail mounted 1.5 A, 24 VDC power supply that can be used to power the 4-20 mA transmitter.

PDA6846-SS 2" U-Bolt Kit



The [PDA6846-SS](#) U-Bolt Kit provides a convenient way to mount the PD6800L to 1.5" or 2" pipes.

PDA-SSTAG Stainless Steel Tag



The [PDA-SSTAG](#) is a laser etched stainless steel tag that can be customized with three lines of text. Each tag comes with a stainless steel wire and lead seal for easy mounting wherever you need.

Dimensions

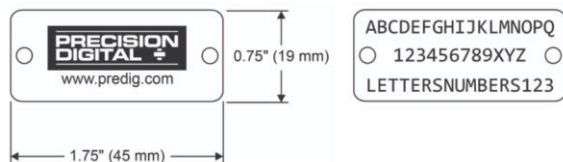

Specifications

Except where noted all specifications apply to operation at +25°C.

General

| | | |
|-------------------------------------|--|--|
| Display | Five digits (-9999 to 99999) | 0.60" (15.2 mm) high, 7-segment, automatic lead zero blanking. |
| | Seven characters | 0.4" (10.2 mm) high, 14-segment. |
| | Symbols | Bargraph which displays process input from 0-100% of scaled value. |
| Display Orientation | Display may be mounted at 90° increments up to 270° from default orientation. | |
| Display Assignment | Lower display may be assigned to custom unit or tag, volume, volume and tag, percent height, percent height and tag, or off. | |
| Display Update Rate | Ambient > -25°C: 2 Updates/Second Ambient < -25°C: 1 Update/5 Seconds | |
| Backlight | White; Loop-powered or externally powered. Backlight can be enabled or disabled via alternative wiring of terminal block. Loop-powered backlight brightness will increase as the input signal current increases. Externally powered backlight has consistent brightness. | |
| Externally Powered Backlight | <i>Voltage Range:</i> 9-36 VDC | |
| | Supply V | 9 VDC 12 VDC 24 VDC 36VDC |
| | Max Pwr | 0.2 W 0.25 W 0.5 W 0.75 W |
| Display Overrange | Display flashes 99999 | |
| Display Underrange | Display flashes -9999 | |
| Programming Method | Four SafeTouch through-glass buttons when cover is installed. Four internal pushbuttons when cover is removed. | |
| Noise Filter | Programmable $L0$, n , E_d , H i , or OFF | |
| Recalibration | Recalibration is recommended at least every 12 months. | |
| Max/Min Display | Max/Min readings reached by the process are stored until reset by the user or until power to the meter is turned off. | |
| Advanced Function | Linear, square root, or programmable exponent | |
| Password | Programmable password restricts modification of programmed settings. | |
| Non-Volatile Memory | All programmed settings are stored in non-volatile memory for a minimum of ten years if power is lost. | |
| Normal Mode Rejection | 64 dB at 50/60 Hz | |
| Environmental | Operating temperature range: -40 to 75°C (-40 to 167°F) Storage temperature range: -55 to 75°C (-67 to 167°F) Installation temperature range: -55 to 75°C (-67 to 167°F) (The display ceases to function below -40°C) Relative humidity: 0 to 90% non-condensing Printed circuit boards are conformally coated | |
| Connections | Screw terminals accept 12 to 22 AWG wire | |
| Mounting | May be mounted directly to conduit. Built-in flange for wall mounting or NPS 1½" to 2½" or DN 40 to 65 mm pipe mounting. See <i>Dimensions</i> on page 13. | |
| Overall Dimensions | 5.65" x 5.25" x 4.86" (W x H x D) (144 mm x 133 mm x 124 mm) | |

| | |
|-----------------|--|
| Weight | Aluminum: 4.8 lbs (2.18 kg) |
| | Stainless Steel: 8.7 lbs (4.3 kg) |
| Warranty | 3 years parts and labor. See Warranty Information and Terms & Conditions on www.predig.com for complete details. |

Input

| | | |
|---|---|---|
| Input | 4-20 mA | |
| Accuracy | ±0.03% of calibrated span ±1 count, square root & programmable exponent accuracy range: 10-100% of calibrated span. | |
| Maximum Voltage Drop & Equivalent Resistance | Without Backlight or with Externally Powered Backlight | With Loop-Powered Backlight |
| | 3.0 VDC @ 20 mA | 6.0 VDC @ 20 mA |
| | 150 Ω @ 20 mA | 300 Ω @ 20 mA |
| Temperature Drift | 50 PPM/°C from -40 to 75°C ambient | |
| Multi-Point Linearization | 2 to 32 points | |
| Decimal Point | User selectable decimal point | |
| Minimum Span | Input 1 & Input 2: 0.10 mA | |
| Calibration Range | An <i>Error</i> message will appear if input 1 and input 2 signals are too close together. | |
| | Input Range | Minimum Span Input 1 & Input 2 |
| | 4-20 mA | 0.10 mA |
| Input Overload | Over current protection to 2 A max. | |
| HART Transparency | The meter does not interfere with existing HART communications; it displays the 4-20 mA primary variable and it allows the HART communications to pass through without interruption. The meter is not affected if a HART communicator is connected to the loop. The meter does not display secondary HART variables. | |

Open Collector Output

| | |
|---------------------|--|
| Rating | Isolated open collector, sinking NPN 30 VDC @ 150 mA max. |
| Alarm Output | Assign to level or volume for high or low alarm trip point. |
| Deadband | 0-100% FS, user selectable |
| Acknowledge | Front panel ENTER button and external RESET terminals resets output and screen indication. |

Enclosure

| | |
|----------------------------|---|
| Material | AL Models: ASTM A413 LM6 die-cast aluminum, copper-free, enamel coated SS Models: ASTM A743 CF8M investment-cast 316 stainless steel |
| Gasket | Fluoroelastomer |
| Rating | NEMA 4X, IP68 Explosion-proof |
| Color | AL: Blue SS: Silver |
| Window | Borosilicate glass |
| Conduits | PD6800-0L1: Two 3/4" NPT PD6800-0L1-M20: Two M20 PD6800-0L1-SS: Two 3/4" NPT PD6800-0L1-SS-M20: Two M20 |
| Flange | Built-in flange for wall and pipe mounting |
| Tamper-Proof Seal | Cover may be secured with tamper-proof seal |
| Instrument Tag Loop | Built-in loop for securing stainless steel tag |
| ATEX & IECEx | Flame-proof protection ⊕ II 2 G D Ex db IIC Gb Ex tb IIIC Db IP66/IP68 Tamb: -55°C to +85°C Certificate No.: Sira 19ATEX1252U Certificate No.: IECEx SIR 19.0075U |
| CSA | Class I, Division 1, Groups A, B, C, D Class II, Division 1, Group E, F, G; Class III Ex db IIC Gb Ex tb IIIC Db Class I, Zone 1, AEx db IIC Gb; Zone 21, AEx tb IIIC Db IP66/IP68/TYPE 4X Tamb: -55°C to +85°C Certificate number: CSA 19.80011200U |
| UL | Class I, Division 1, Groups A, B, C and D Class II, Division 1, Groups E, F and G Class III; Class I, Zone 1, AEx db IIC Gb Zone 21, AEx tb IIIC Ex db IIC Gb Ex tb IIIC Db IP66/IP68/TYPE 4X Tamb: -55°C to +85°C Certificate Number: E518920 |

Note: The above approvals are for the enclosure only. See *Product Ratings and Approvals* on page 11 for approvals on the entire instrument.

General Compliance Information

Electromagnetic Compatibility

- EMC Emissions**
- CFR 47 FCC Part 15 Subpart B Class A emissions requirements (USA)
 - ICES-003 Information Technology emissions requirements (Canada)
 - AS/NZS CISPR 11 Group 1 Class A ISM emissions requirements (Australia/New Zealand)
 - EN 55011 Group 1 Class A ISM emissions requirements (EU)
 - EN 61000-6-4 Emissions requirements for Heavy Industrial Environments - Generic

EMC Emissions and Immunity EN 61326-1 EMC requirements for Electrical equipment for measurement, control, and laboratory use – industrial use

Product Ratings and Approvals

CSA Explosion-proof for use in:
 Class I, Division 1, Groups B, C and D
 Dust-ignition-proof for use in:
 Class II/III, Division 1, Groups E, F and G; T6
 Flame-proof for use in:
 Zone 1, Ex d IIC T6
 Ta = -55 to 75°C
 Enclosure: Type 4X & IP66/IP68
 Certificate number: CSA 11 2325749

ATEX Explosion-proof for use in:
 II 2 G D
 Ex db IIC T6 Gb
 Ex tb IIIC T85°C Db IP68
 Ta = -55 to 75°C
 Certificate number: Sira 10ATEX1116X

IECEx Explosion-proof for use in:
 Ex db IIC T6 Gb
 Ex tb IIIC T85°C Db IP68
 Ta = -55 to 75°C
 Certificate number: IECEx SIR 10.0056X

ATEX/IECEx Specific Conditions of Use

1. The equipment label and epoxy coating may generate an ignition-capable level of electrostatic charges under certain extreme conditions. The user should ensure that the equipment is not installed in a location where it may be subjected to external conditions (such as high-pressure steam) which might cause a buildup of electrostatic charges on non-conducting surfaces. Additionally, cleaning of the equipment should be done only with a damp cloth.
2. Flameproof joints are not intended to be repaired.
3. All entry closure devices shall be suitably certified as “Ex d”, “Ex t” and “IP66/68” as applicable. Suitable thread sealing compound (non-setting, non-insulating, non-corrosive, not solvent based, suitable for the ambient rating) must be used at the NPT conduit entries to achieve the IPx8 rating while maintaining the Ex protection concept.

Year of Construction

This information is contained within the serial number with the first four digits representing the year and month in the YYMM format.

For European Community:

The PD68XX Series must be installed in accordance with the ATEX directive 2014/34/EU, the product certificate Sira 10ATEX1116X, and the product manual.

EU Declaration of Conformity

For shipments to the EU and UK, a Declaration of Conformity was printed and included with the product. For reference, a Declaration of Conformity is also available on our website www.predig.com/docs.

Safety Information

⚠ CAUTION

- Read complete instructions prior to installation and operation of the annunciator.

⚠ WARNINGS

- Risk of electric shock or personal injury.
- Hazardous voltages exist within enclosure.
- Installation and service should be performed only by trained service personnel.
- Service requiring replacement of internal components must be performed at the factory.
- In hazardous areas, conduit and conduit/stopping plugs require the application of non-setting (solvent free) thread sealant. It is critical that all relevant hazardous area guidelines be followed for the installation or replacement of conduit or plugs.

Installation

For Installation in USA: The PD68XX Series must be installed in accordance with the National Electrical Code (NEC) NFPA 70.

For Installation in Canada: The PD68XX Series must be installed in accordance with the Canadian Electrical Code CSA 22.1. All input circuits must be derived from a CSA approved Class 2 source.

For European Community: The PD68XX Series must be installed in accordance with the ATEX directive 2014/34/EU and the product certificate Sira 10ATEX1116X.

⚠ WARNINGS

- Disconnect from supply before opening enclosure.
- Keep cover tight while circuits are live.
- Conduit seals must be installed within 18" (450 mm) of the enclosure.
- Use suitably certified and dimensioned cable entry device and/or plug.
- Cable must be suitable for 90°C.

All controls and wiring connections are located on the display module that is accessed by removing the enclosure cover. The controls can be accessed without removing the display module. The wiring connections can be accessed by removing the display module which is secured to the enclosure by two captive screws.

Unpacking

Remove the meter from box. Inspect the packaging and contents for damage. Report damages, if any, to the carrier. If any part is missing or the meter malfunctions, please contact your supplier or the factory for assistance.

Cover Jam Screw



The cover jam screw should be properly installed once the meter has been wired and tested in a safe environment. The cover jam screw is intended to prevent the removal of the meter cover in a hazardous environment without the use of tools. Using a M2 hex wrench, turn the screw clockwise until the screw contacts the meter. Turn the screw an additional 1/4 to 1/2 turn to secure the cover.

⚠ CAUTION

- Excess torque may damage the threads, screw head, or wrench.

Mounting

The PD68XX Series includes a built-in mounting flange that may be used for pipe mounting or wall mounting. Alternatively, the unit may be supported by the conduit using the conduit holes provided.

Refer to *Figure 1* and *Figure 2*.

⚠ WARNING

- Do not attempt to loosen or remove flange bolts while the meter is in service.

Dimensions

All units: inches (mm)

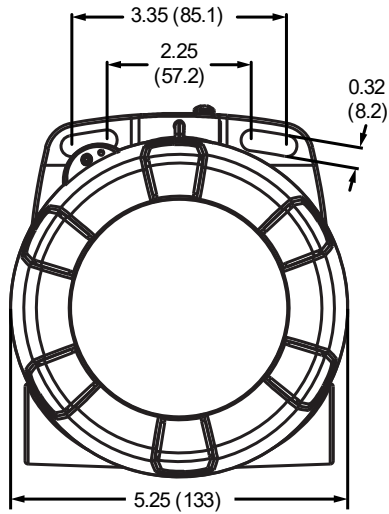

Figure 1. Enclosure Dimensions - Front View

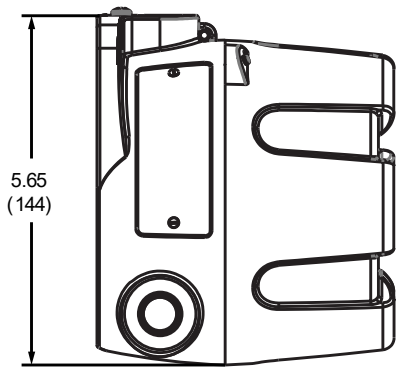

Figure 2. Enclosure Dimensions - Side View

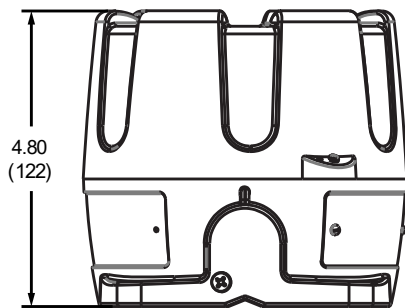

Figure 3. Enclosure Dimensions - Top View



Download free 3-D CAD files of these instruments to simplify your drawings!

predig.com/documentation-cad

Connections

To access the connectors, remove the enclosure cover and unscrew the two captive screws that fasten the display module. Disconnect the ribbon cable and remove the display module. Signal connections are made to a four-terminal connector in the base of the enclosure. Grounding connections are made to the two ground screws provided on the base – one internal and one external.

| | |
|--------------------|--|
| SIGNAL + | 4-20 mA signal input positive terminal connection |
| SIGNAL - | 4-20 mA signal return/negative terminal connection when not using loop powered backlight. |
| BACKLIGHT + | +9-36 VDC when powering backlight from external supply. |
| BACKLIGHT - | 4-20 mA signal return/negative terminal when using the installed loop powered backlight or ground/negative when powering backlight from external supply. |
| OUTPUT+ | NPN open collector output positive. |
| OUTPUT- | NPN open collector output negative. |
| RESET + | Contact closure alarm acknowledge, pull up to 3 VDC. |
| RESET- | Contact closure alarm acknowledge ground/negative. |

Refer to *Figure 4* for terminal positions.

⚠ WARNINGS

- Observe all safety regulations. Electrical wiring should be performed in accordance with all agency requirements and applicable national, state, and local codes to prevent damage to the meter and ensure personnel safety.
- Static electricity can damage sensitive components.
- Observe safe handling precautions for static-sensitive components.
- Use proper grounding procedures/codes.
- If the meter is installed in a high voltage environment and a fault or installation error occurs, high voltage may be present on any lead or terminal.

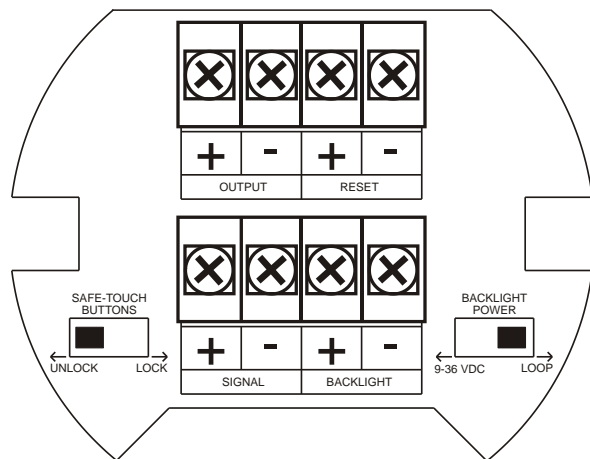

Figure 4. Connector Board

Wiring Diagrams

Signal connections are made to a four-terminal connector mounted in the base of the enclosure per *Figure 4. Connector Board*. The enclosure also provides one internal and one external earth grounding screw.

For installations that don't use the backlight, the maximum voltage drop is 3 V and connections are made per *Figure 5*.

For installations that use the backlight powered from the loop, the maximum voltage drop is 6 V and connections are made per *Figure 6*.

For installations that use the backlight powered from an external source, the maximum voltage drop is 3 V and connections are made per *Figure 7*.

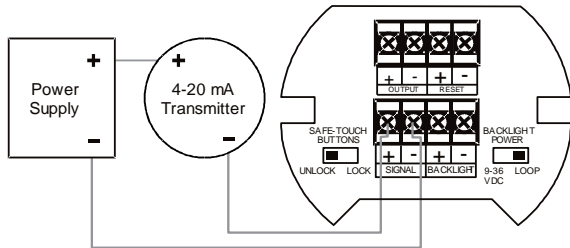

Figure 5. Connections without Backlight

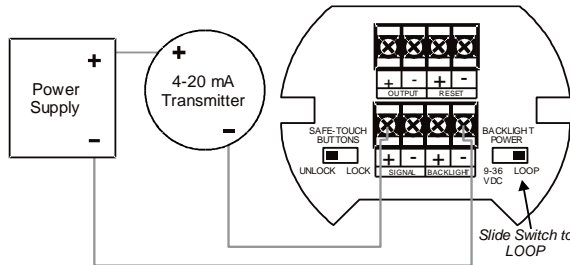

Figure 6. Connections with Loop-Powered Backlight

Loop-powered backlight brightness will increase as the input signal current increases. If constant backlight brightness is desired, the backlight should be powered by an external source.

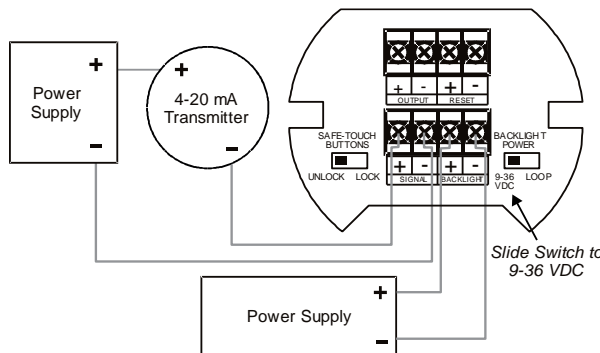

Figure 7. Connections with Externally-Powered Backlight

It is possible to use the same transmitter (signal loop) power supply for the externally powered backlight. The backlight circuit will draw 25 mA in addition to the loop circuit.

External Acknowledge Connection

External acknowledge connections are made to two terminals labeled RESET. Connect to a contact closure source such as a relay or a pushbutton as shown in *Figure 7*.

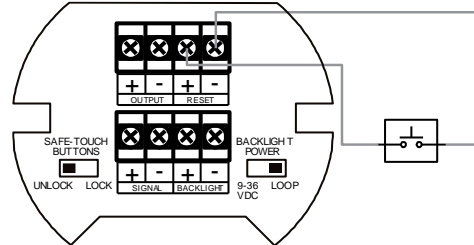

Figure 8. External Alarm Reset/Acknowledge Connections

Open Collector Output Connections

Output connections are made to two terminals labeled OUTPUT. The output can be connected to an input device such as alarm indicator as shown in *Figure 8*, or to drive a relay as shown in *Figure 9*.

WARNING

- To avoid damaging the PD6800-0L1's amplifying components, use care not to wire incorrectly or exceed output ratings. A diode, such as 1N4000 series, will provide protection from relay transients.

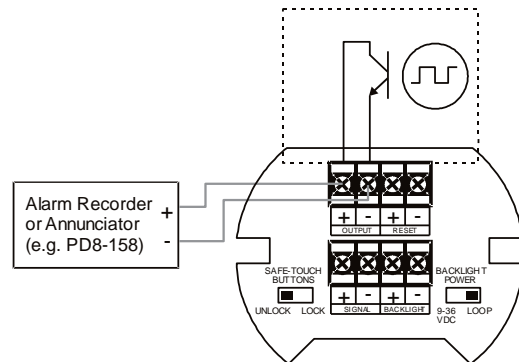

Figure 9. Connection to Device with Internal Pull-Up

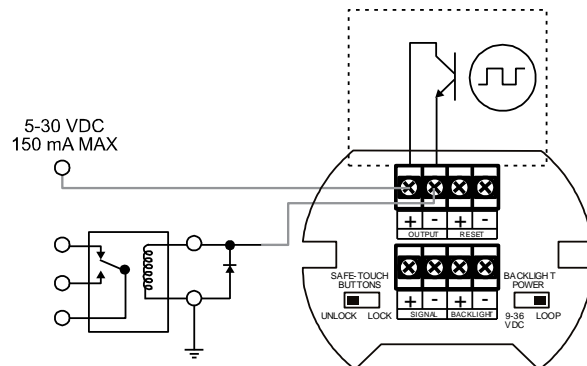

Figure 10. Output Connections

Setup and Programming

There is **no need to recalibrate** the meter when first received from the factory. Simply scale the meter to display the process in engineering units.

The meter is **factory calibrated** and it is scaled to read 0.0 to 100.0%, which correspond to a 4-20 mA input. The calibration equipment is traceable to NIST standards.

Overview

Setup and programming is done through the infrared through-glass SafeTouch buttons or using the mechanical buttons when uncovered. There are two slide switches located on the connector board. One is used to select backlight power and the other is to lock or unlock the SafeTouch Buttons.

After all connections have been completed and verified, connect the ribbon cable to the display module, fasten the display module to the base, install enclosure cover, and then apply power.

SafeTouch Buttons

The PD6800-0L1 is equipped with four sensors that operate as through-glass buttons so that it can be programmed and operated without removing the cover (and exposing the electronics) in a hazardous area. These buttons can be disabled for security by selecting the LOCK setting on the SAFE-TOUCH BUTTONS switch located on the connector board in the base of the enclosure.

SafeTouch Button Operation

To actuate a button, press and remove one finger to the glass directly over the marked button area. Remove finger to at least 4 inches away from the glass in between button activations. SafeTouch and mechanical buttons may be held to cycle through menus or digits in place of repeatedly pushing a button. The sensors are disabled when a mechanical button is pressed and will automatically be re-enabled after 60 seconds of inactivity.

SafeTouch Button Tips and Troubleshooting

The SafeTouch buttons are designed to filter normal levels of ambient interference and to protect against false triggering, however, it is recommended that the SafeTouch buttons be disabled (slide switch to LOCK) if there is an infrared interference source in line-of-sight to the display.

SafeTouch Button Tips:





- To the extent possible, install the display facing away from sunlight, windows, reflective objects and any sources of infrared interference.
- Keep the glass window clean.
- Tighten the cover securely.
- Use a password to prevent tampering.
- If the cover has not been installed and secured tightly, it may take a moment for the SafeTouch buttons to properly self-calibrate when the cover is tightened.

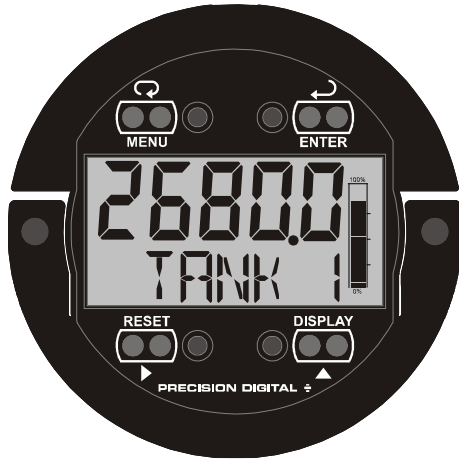

IMPORTANT

- SafeTouch buttons will not work if two or more buttons are detected as being pressed simultaneously. As a result, be careful to avoid triggering multiple buttons or reaching across one button location to press another.

Buttons and Display



| Button Symbol | Description |
|---|-------------------|
|  | Menu |
|  | Right arrow/Reset |
|  | Up arrow/Display |
|  | Enter |

| Symbol | Status |
|--|--|
|  | 20-Segment Tank Level Indicator Bargraph |
|  | Password Enabled |

Menu Button

- Press the **Menu** button to enter Programming Mode.
- Press the **Menu** button during Programming Mode to return to the previous menu selections.
- Hold the **Menu** button for 1.5 seconds at any time to exit Programming Mode and return to *Run Mode*.
- Press and hold the **Menu** button for 5 seconds to access the *Advanced Features* of the meter.

Right / Reset Button

- Press the Right arrow button to reset the maximum or minimum value while it is being displayed (see **Up / Display Button** below).
- Press the **Right** arrow button to move to the next digit or decimal position during programming.
- Press **Right** to go backward through most selection menus.

Up / Display Button

- Press Display when in Run Mode to cycle through displaying the maximum value, minimum value, and the loop input value in mA. The display will time out in 12 seconds. Press Display again to resume normal lower display operation (lower display will read RESUME).
- Press the **Up** arrow button to scroll forward through the menus, decimal point, or to increment the value of a digit.

Enter Button

- Press the **Enter** button to access a menu or to accept a setting.
- Press **Enter** to acknowledge alarm (if enabled).

Main Menu Display Functions & Messages

The meter displays various functions and messages during setup, programming, and operation. The following table shows the main menu functions and messages in the order they appear in the menu.

| Display | Parameter | Action/Setting |
|---------|----------------------|--|
| SETUP | Setup | Enter Setup menu |
| DECIMAL | Decimal Point | Enter the decimal point location |
| SCALE | Scale | Enter the Scale menu for engineering units |
| INPUT 1 | Input 1 | Set input 1 value in mA |
| DISP 1 | Display 1 | Set display 1 engineering units |
| INPUT 2 | Input 2 | Set input 2 value in mA |
| DISP 2 | Display 2 | Set display 2 engineering units |
| SAVE ? | Save? | Save entered scale parameters? |
| SPN ERR | Span Error | Scale point 1 and 2 span error |
| PERCENT | Percent | Scale the tank indicator full and empty values |
| 0 PCT | 0 Percent | Set the tank empty value |
| 100 PCT | 100 Percent | Set the tank full value |
| DISPLAY | Display | Enter Bottom Display menu |
| TAG | Tag | Display a custom unit or tag |
| VOLUME | Volume | Display volume |
| VOL+TAG | Volume + Tag | Display volume and custom tag |
| PCT HT | Percent Height | Display percent height |
| PCT+TAG | Percent Height + Tag | Display percent height and custom tag |
| OFF | Off | Disable lower display |
| ADVANCE | Advanced | Advanced Features Menu (See Advanced Features Menu (ADVANCE) on page 22) |
| PASSWD | Password | Enter the Password menu |
| UNLOCK | Unlocked | Program password to lock meter |
| LOCKED | Locked | Enter password to unlock meter |
| SETUP | Setup | Enter Setup menu |

Main Menu

The main menu consists of the most commonly used functions: *Setup*, *Advanced*, and *Password*. Press **MENU** button to enter *Programming Mode* then press the **Up Arrow** button to scroll through the main menu.

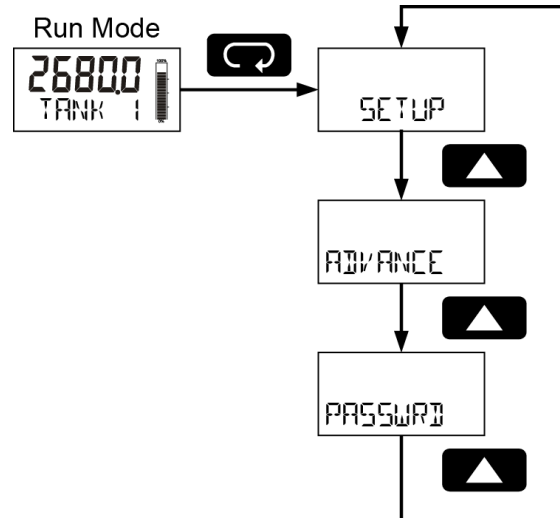

Hold **MENU**, at any time, to exit and return to *Run Mode*. Changes made to settings prior to pressing **ENTER** are not saved.

Press the **MENU** button during *Programming Mode* to return to the previous menu selections.

Changes to the settings are saved to memory only after pressing **ENTER**.

The display moves to the next menu every time a setting is accepted by pressing **ENTER**.

Setting Up the Meter (SETUP)

The *Setup* menu is used to select:

1. Decimal point location
2. Scale in engineering units
3. Tank indicator 0 and 100%
4. Lower display selection
5. Turn on/off bargraph (Tank indicator)

Press the **ENTER** button to access any menu or press **UP** arrow button to scroll through choices.

Hold **MENU**, at any time, to exit and return to Run Mode. Changes made to settings prior to pressing **ENTER** are not saved.

Press the **MENU** button during Programming Mode to return to the previous menu selections.

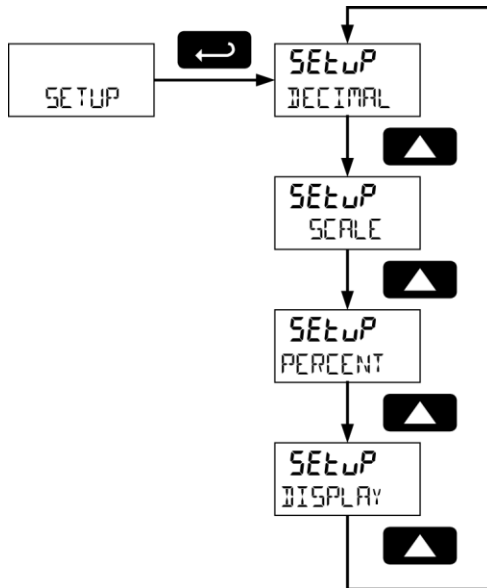

Setting Numeric Values

The numeric values are set using the **RIGHT** and **UP** arrow buttons. Press **RIGHT** arrow to select next digit and **UP** arrow to increment digit.

The digit being changed blinks.

Press the **ENTER** button, at any time, to accept a setting.

Hold **MENU**, at any time, to exit and return to Run Mode. Changes made to settings prior to pressing **ENTER** are not saved.

Press the **MENU** button during Programming Mode to return to the previous menu selections.

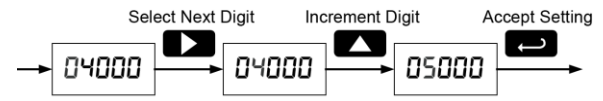

Note: The currently selected digit will blink. Pressing the Right Arrow button will select the next digit, causing it to blink.

Setting the Level Decimal Point (DECIMAL)

Decimal point may be set with up to four decimal places or with no decimal point.

Pressing the **Right** arrow moves the decimal point one place to the right and pressing the **Up** arrow moves the decimal point one place to the left.

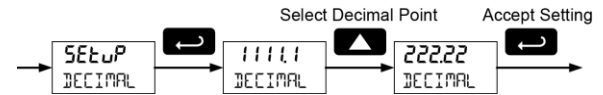

Scaling the Meter (SCALE)

The 4-20 mA input can be scaled to display the process in engineering units. To scale the meter, enter the value in milliamps (mA) for input 1, and then the corresponding engineering units display value. Do the same for input 2.

After entering the display 2 value, confirm the new scale by pressing **ENTER** at the Save menu.

A signal source is not needed to scale the meter; simply program the inputs and corresponding display values.

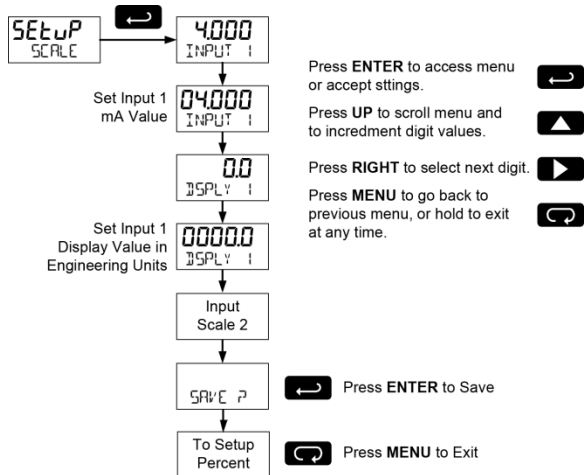

For instructions on using multipoint scaling, see *Level Input Multipoint Linearization (MULTIPOINT)* on page 25.

Minimum Input Span

The minimum input span is the minimum difference between input 1 and input 2 signals required to complete the calibration or scaling of the meter. The minimum span is 0.10 mA.

Scale Error Message (SPAN ERR)

If the minimum span is not maintained, the meter will show a span error (SPAN ERR) and revert to input 1, allowing the appropriate input signals to be applied.

Note: The Scale and Calibrate functions are exclusive of each other. The meter uses the last function programmed. Only one of these methods can be employed at a time. The Scale and Calibrate functions can use up to 32 points (default is 2). The multi-point linearization should be enabled in the Advanced Features menu under the Level Input Multipoint Linearization (MULTIPOINT) menu selection, prior to scaling and calibration of the meter, see *Advanced Features Menu (ADVANCE)* on page 22.

Scaling the Tank Level Indicator (PERCENT)

The display includes a 20-segment tank level indicator. This menu sets full and empty values, in engineering units, for the tank level indicator.

This value may differ from the 20 mA full-scale and 4 mA empty-scale values programmed in the *Scale* menu. This is ideal for level transmitters that output less than 20 mA at the maximum height of the tank or pit or more than 4 mA at the minimum height.

As an example, when using a level transmitter that outputs 20 mA at 25 meters, the tank height indicator may be set for a maximum of 10 meters. When the meter reaches 10 meters on the display, the tank height indicator will show full, even though the input is not 20 mA.

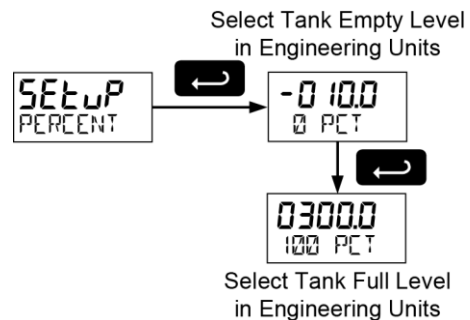

Configuring the Display (DISPLAY)

The lower (BOTTOM) display may be configured to display a custom tag (TAG), volume (VOLUME), volume and tag (VOL+TAG), percent of full height (PCT HT), percent of full height and tag (PCT+TAG), or be blank (OFF).

A custom tag of up to seven alphanumeric characters may be programmed for identification (e.g. TANK 3) or for engineering units (e.g. GALLONS).

Percent full height shows the percent full of the tank height level indicator programmed in the *Scaling the Tank Level Indicator (PERCENT)* menu.

The tank level indicator (GRAPH) may also be turned on or off from the display menu.

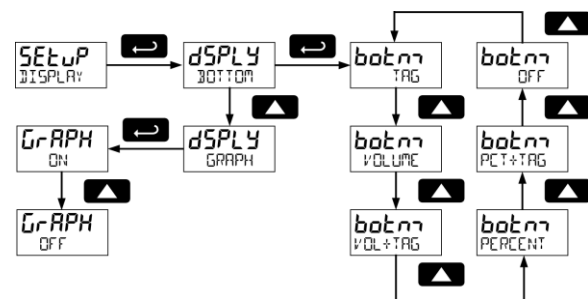

Note: Volume is a separate, second scale of the input process variable. This is configured in *Volume Display Scaling (VOLSCALE)* on page 24.

Setting the Tag (TAG)

Any lower display setting that includes a tag will require the tag to be entered.

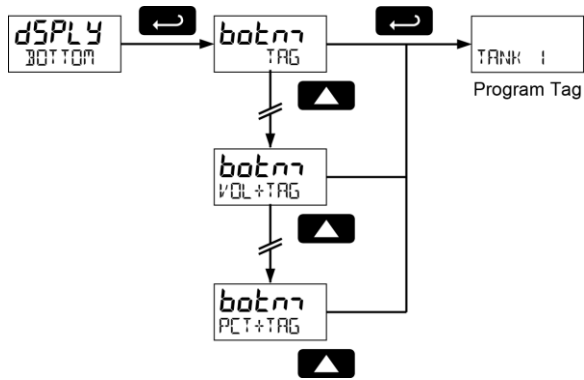

The fully alphanumeric values for the tag are set using the **RIGHT** button to select the digit, the **UP** and **RIGHT** arrow buttons to select the digit reading, and the **ENTER** button to confirm and select the next digit.

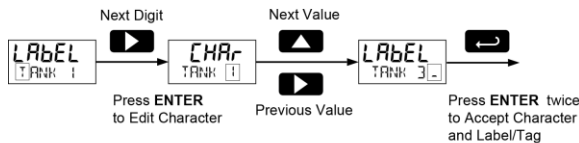

Setting Up the Password (PASSWRD)

The *Password* menu is used to program a five-digit password to prevent unauthorized changes to the programmed parameter settings. A password protected meter will display **LOCKED** when the **MENU** button is pressed.

Locking the Meter

Enter the *Password* menu and program a five-digit password.

For instructions on how to program numeric values see *Setting Numeric Values*, page 19.



Record the password for future reference. If appropriate, it may be recorded in the space provided.

| | |
|----------------|-------------|
| Model: | |
| Serial Number: | |
| Password: | ___ _ _ _ _ |

Making Changes to a Password Protected Meter

If the meter is password protected, the meter will display the message **LOCKED** when the Menu button is pressed. Press the Enter button while the message is being displayed and enter the correct password to gain access to the menu. After exiting the programming mode, the meter returns to its password protected condition.

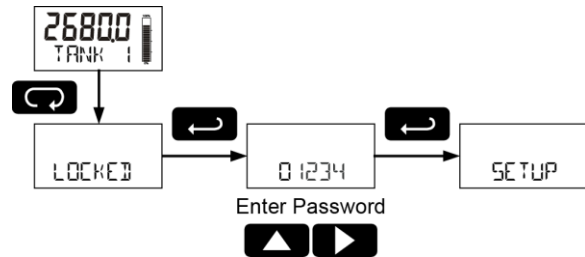

Disabling Password Protection

To disable the password protection, access the *Password* menu and enter the correct password, as shown below.

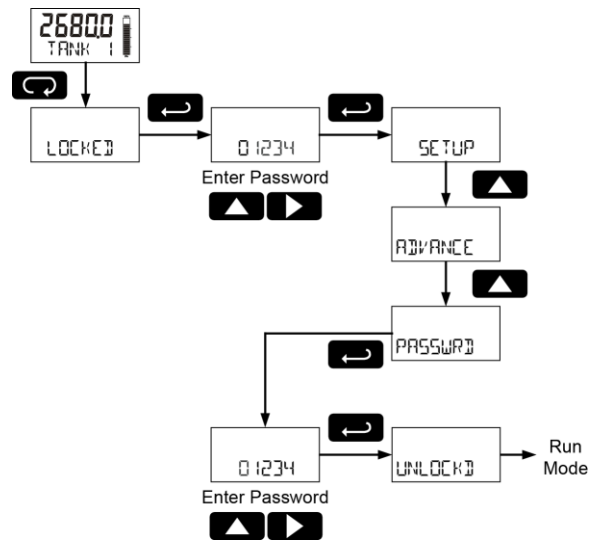

If the correct five-digit password is entered, the meter displays the message **UNLOCKED** (*unlocked*) and the protection is disabled until a new password is programmed.

If the password entered is incorrect, the meter displays the message **LOCKED** and returns to Run Mode. To try again, repeat the above procedure.

Did you forget the password?
 The password may be disabled by entering a master password. If you are authorized to make changes, enter the master password 50865 to unlock the meter.

Advanced Features Menu (ADVANCE)

To simplify the setup process, functions not needed for most applications are located in the *Advanced Features Menu*. Access the *Advanced Features Menu* by pressing **ENTER** at the **ADVANCE** menu in the *Main Menu* defined on page 18.

The *Advanced Features Menu* is used to select:

1. Open collector output configuration (OUTPUT)
2. Input filter (FILTER)
3. Volume display scale (VOLSCAL)
4. Live signal level display calibration (LVL CAL)
5. Internal Calibration (ICAL)
6. Multipoint linearization enable (MULTIPT)
7. Meter system information display (INFO)

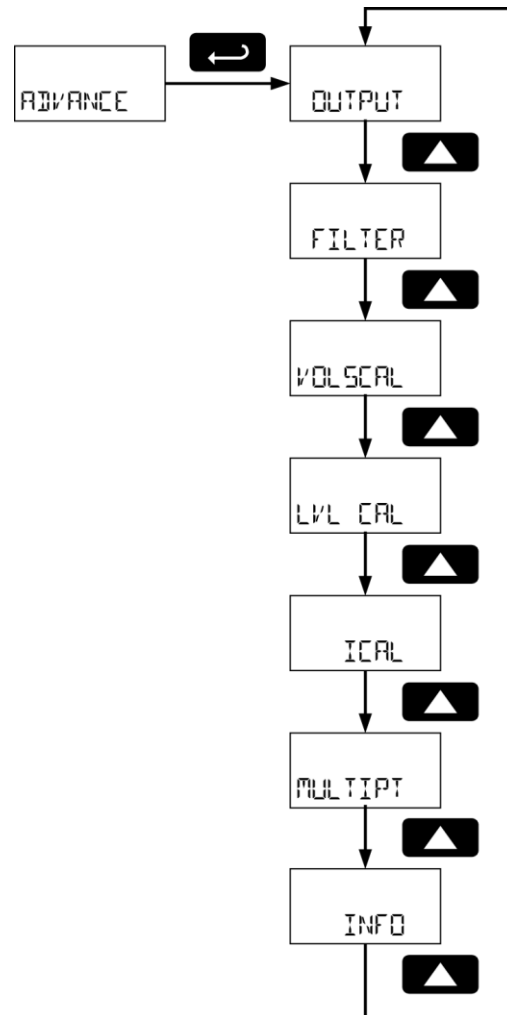

Advanced Features Menu & Display Messages

The following table shows the *Advanced* features menu functions and messages in the order they appear in the menu.

| Display | Parameter | Action/Setting |
|-------------|-------------------------|---|
| OUTPUT | <i>Output</i> | Enter output menu |
| OFF | <i>Off</i> | Disable output |
| ALARM | <i>Alarm Output</i> | Enter alarm output menu |
| LEVEL | <i>Level Alarm</i> | Assign alarm output to level |
| SET | <i>Set Point</i> | Set alarm set point |
| RESET | <i>Reset Point</i> | Set alarm reset point |
| VOLUME | <i>Volume Alarm</i> | Assign alarm output to volume |
| FILTER | <i>Filter</i> | Set noise filter |
| LO | <i>Filter Low</i> | Set noise filter to low setting |
| Med | <i>Filter Medium</i> | Set noise filter to medium setting |
| HI | <i>Filter High</i> | Set noise filter to high setting |
| OFF | <i>Filter Off</i> | Disable noise filter |
| VOLSCALE | <i>Volume Scale</i> | Scale the volume display |
| VOL DECIMAL | <i>Volume Decimal</i> | Set the decimal position for volume scaling |
| NO PTS | <i>Number of Points</i> | Set the number of points for volume scaling |
| INPUT 1 | <i>Input 1</i> | Set volume input 1 on the level display |
| DISPLY 1 | <i>Display 1</i> | Set volume display 1 |
| INPUT 2 | <i>Input 2</i> | Set volume input 2 on the level display |
| DISPLY 2 | <i>Display 2</i> | Set volume display 2 |

| Display | Parameter | Action/Setting |
|-----------|-----------------------------|--|
| SAVE P | <i>Save</i> | Save entered volume scale parameters |
| LVL CAL | <i>Level Calibration</i> | Calibrate the level display |
| INPUT 1 | <i>Input 1</i> | Calibrate input 1 value |
| DISPLY 1 | <i>Display 1</i> | Set display 1 feet and inches |
| INPUT 2 | <i>Input 2</i> | Calibrate input 2 value |
| DISPLY 2 | <i>Display 2</i> | Set display 2 feet and inches |
| SAVE P | <i>Save</i> | Save entered calibration parameters |
| ICAL | <i>Internal Calibration</i> | Enter internal reference calibration |
| 4.000 | <i>4.000 mA</i> | Calibrate input at 4 mA |
| 20.000 | <i>20.000 mA</i> | Calibrate input at 20 mA |
| SPAN ERR | <i>Span Error</i> | Error with calibration point 1 and 2 span |
| MULTIPT | <i>Multipoint</i> | Set level display multipoint linearization |
| DISABLE | <i>Disable</i> | Disable multipoint linearization |
| ENABLE | <i>Enable</i> | Enable multipoint linearization |
| INFO | <i>Meter Information</i> | Show software number and version, or reset to factory defaults |
| SOFT | <i>Software</i> | Software number |
| VER | <i>Software Version</i> | Software version |
| DEFAULTSP | <i>Reset to Defaults?</i> | Restore factory default parameter settings |

Alarm Output (OUTPUT)

The PD6800-0L1 is equipped with an NPN open collector output that may be set up for high or low alarm trip point based on the level display (LEVEL) or the volume scale (VOLUME). The output may be disabled by selecting OFF.

When the alarm is enabled for level and the alarm set point has been reached, the level display will flash, accompanied by the lower display alternating between normal display and ALARM. A tank height indicator segment will flash at the level the alarm is set to while the level indicator is at or above the alarm point.

When the alarm is enabled for volume and the alarm set point has been reached, the lower display will flash, alternating between its normal display and ALARM.

To set a high alarm, program the set point value to be greater than the reset point.

To set a low alarm, program the set point value to be less than the reset point.

To acknowledge an alarm, press the **ENTER** button once for acknowledge prompt and a second time to confirm. Acknowledging an alarm will turn off the alarm output and stop the display from flashing. The lower display will continue to alternate between its normal display and ALARM until the alarm condition is cleared.

The alarm status will show on the display even if the output is not wired.

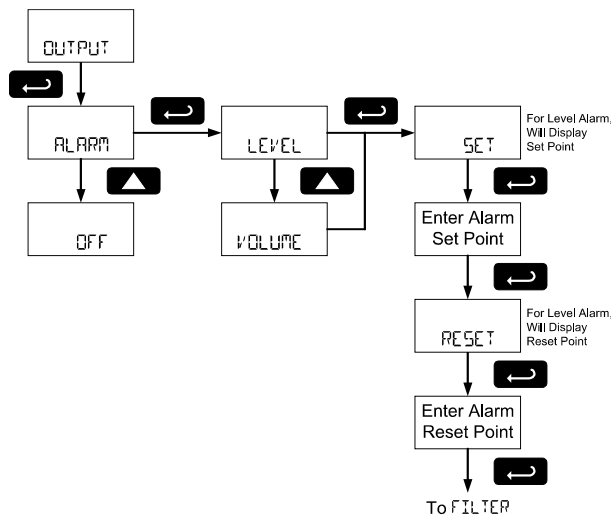

Input Signal Filter (FILTER)

The noise filter is available for unusually noisy signals that cause an unstable process variable display. The noise filter averages the input signal over a certain period. The filter level can be set to low (LO), medium (MED), high (HI), or off (OFF). The higher the filter setting, the longer the averaging time and so the longer the display may take to find its final value.

The filter contains a noise filter bypass feature so that while small variations in the signal will be filtered out, large, abrupt changes to the input signal are displayed immediately.

Volume Display Scaling (VOLUME)

Volume may be scaled as a function of the level display. It may use up to 32-point linearization. The multi-point linearization can be used to linearize the display for non-linear signals such as those from level transmitters used to measure volume in odd-shaped tanks.

To scale the volume display, select the decimal point location (0, 1, 2, 3, or 4), then enter the level in engineering units for input 1, the corresponding volume display value, and the same for input 2.

After entering the display 2 value, confirm the new volume scale by pressing **ENTER** at the Save menu.

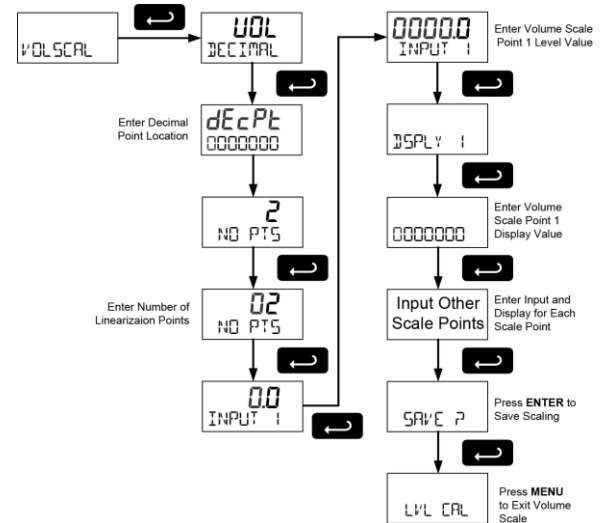

Note:
To display the volume, see *Configuring the Display (DISPLAY)* on page 20.

Level Input Live Signal Calibration (LVL CAL)

The meter can be calibrated using a current source instead of scaling. This process will override previously programmed scaling of the level display. The use of a calibrated signal source is strongly recommended.

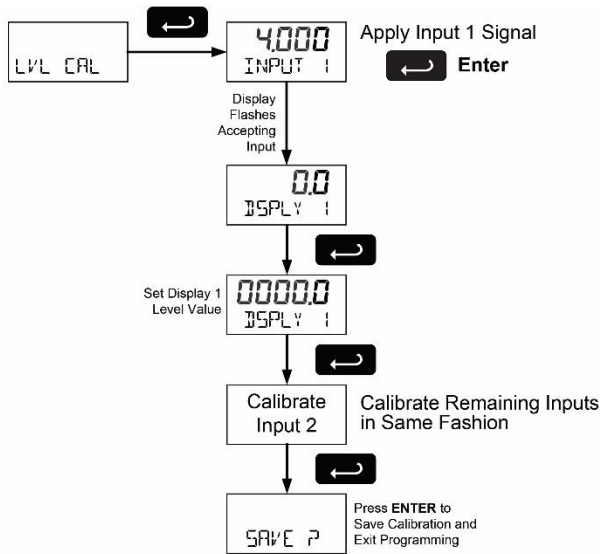

Internal Calibration (ICAL)

There is **no need to recalibrate** the meter when first received from the factory. The meter is **factory calibrated** prior to shipment. The calibration equipment is traceable to NIST standards.

The internal calibration is the meter's master calibration that makes scaling the meter without a signal source possible. Use of a calibrated signal source is necessary to perform an internal calibration of the meter. Check calibration of the meter at least every 12 months. Incorrect calibration will affect the ability of the meter to properly read, scale, and display the input.

Press **MENU**, navigate to **ADVANCE** and press **ENTER** to access the *Advanced Features Menu*. Press the **UP** arrow button to scroll to the *Internal Calibration* menu (**ICAL**) and press **ENTER**.

The meter displays **4.000**. Apply a 4.000 mA signal and press **ENTER**. The display flashes for a moment while the meter is accepting the signal. After the signal is accepted, the meter displays **20.000**. Apply a 20.000 mA signal and press **ENTER**. The display flashes for a moment while the meter is accepting the signal.

Notes:

1. The signal source must have a full-scale accuracy of 0.002% or better between 4 and 20 mA in order to maintain the specified accuracy of the meter.
2. Allow the meter to warm up for at least 15 minutes before performing the calibration procedure.

Calibration Error Message (SPN ERR)

An error message indicates that the calibration process was not successful. After the error message is displayed, the meter will revert to the **INPUT 1** calibration menu. The error message might be caused by inadvertently leaving the signal at the previous level or not maintaining the minimum span. Press the **MENU** button to cancel the current calibration process if necessary.

Level Input Multipoint Linearization (MULTIPT)

This menu enables multipoint linearization for scaling and calibrating of the level display.

Setting **MULTIPT** to **ENABLE** allows the level display to be scaled or calibrated using up to 32 points. See *Scaling the Meter (SCALE)* on page 20 and *Level Input Live Signal Calibration (LVL CAL)* on page 25, to include a *Number of Points (NO PTS)* parameter before entering *Input 1*. The 32-point linearization is used to linearize the display for non-linear signals.

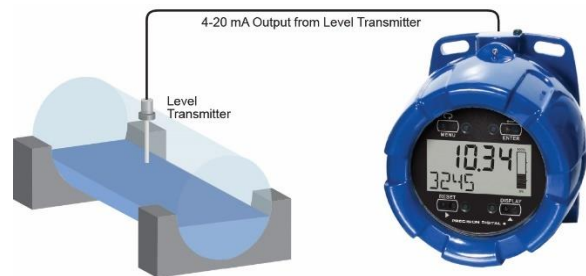

PD6800L Displaying Height in Feet and Volume (Using Multi-Point Linearization Feature) in Gallons in a Round Horizontal Tank.

Information (INFO)

The *Information* menu shows the software identification number and version number. To determine the software version of a meter:

Go to the *Information* menu (**INFO**) and press **ENTER** button.

Continue pressing **ENTER** to scroll through the software release number and software version.

Following the information display, the meter will exit the *Advanced Features* menu and return to run mode.

Operation

Front Panel Buttons Operation

| Button Symbol | Description |
|---------------|--|
| | Press to Enter or Exit Programming Mode |
| | Used to Reset Maximum and Minimum Values |
| | Press to Cycle Displaying Maximum Value, Minimum Value, and Input Current in mA Press to Resume Run Mode in Lower Display |
| | Press to Acknowledge Alarm (if Enabled) |

Display Maximum, Minimum, and Input Current

The maximum and minimum values and the measured input loop current may be displayed temporarily on the lower display. To display these values, press the **DISPLAY** button. The meter will display the word **MAXIMUM** on the lower display and the maximum value reached (since the last maximum reset) on the top display. Press the **DISPLAY** button again and the meter will display the word **MINIMUM** on the lower display and the minimum value reached on the top display. Pressing the **RESET** button while either of these values is displayed will reset that value to the current display value.

Press the **DISPLAY** button a third time and the meter will display **LOOP MA** on the lower display and the measured input current in milliamps (mA) on the top display. The current display will remain for 10 seconds and then the lower display will return to normal run mode as programmed in *Configuring the Display (DISPLAY)* on page 20. Press the **DISPLAY** button a fourth time to return to the normal operation. The meter will display **RESUME** followed by the run mode lower display.

Reset Meter to Factory Defaults

When the parameters have been changed in a way that is difficult to determine what's happening, it might be better to start the setup process from the factory defaults.

Instructions to load factory defaults:

Enter the *Advanced Features Menu*.

Press and hold **Reset** button when **INFO** is shown. For information on navigating to the *Information menu*, refer to *Advanced Features Menu (ADVANCE)* on page 22.

Press **Enter** when **RESET DEFAULTS** prompt is shown.

Note: If **Enter** is not pressed within three seconds, the prompt will stop flashing return to showing **INFO**.

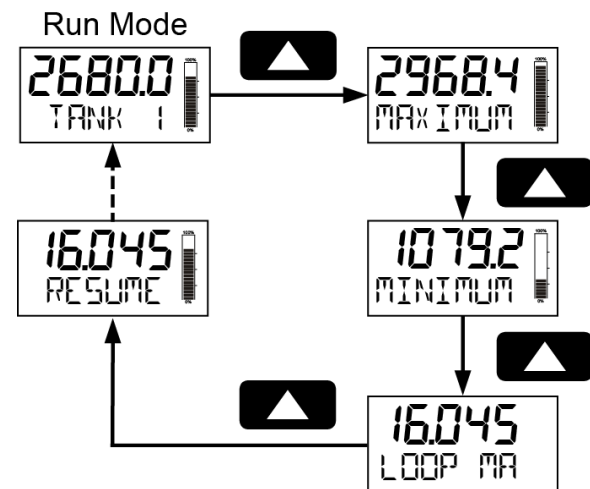
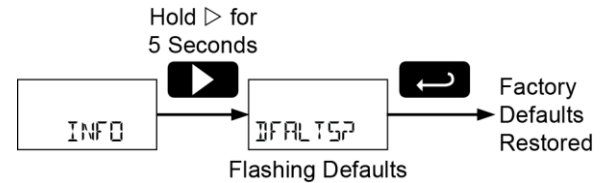

Factory Defaults & User Settings

The following table shows the factory setting for most of the programmable parameters on the meter. Next to the factory setting, the user may record the new setting for the particular application.

Model: _____

S/N: _____

Date: _____

| Parameter | Display | Default Setting | User Setting |
|-------------------------------|----------------|---------------------|--------------|
| Basic Setup | | | |
| Level Decimal Point | DECIMAL | 1111.1 | |
| Input 1 | INPUT 1 | 4.000 mA | |
| Display 1 | DISPLY 1 | 0.0 | |
| Input 2 | INPUT 2 | 20.00 mA | |
| Display 2 | DISPLY 2 | 100.0 | |
| Tank Indicator 0% | 0 PCT | 0.0 | |
| Tank Indicator 100% | 100 PCT | 100.0 | |
| Lower Display | BOTTOM | Tag | |
| Bargraph | GRAPH | On | |
| Tag | TAG | TANK 1 | |
| Advanced Features | | | |
| Output | OUTPUT | Off | |
| Filter | FILTER | Low | |
| Volume Decimal Point | VOL DECIMAL | 0000000 | |
| Volume Scale Number of Points | NO PTS | 02 | |
| Volume Scale Input 1 | INPUT 1 | 0.0 | |
| Volume Display 1 | DISPLY 1 | 0 | |
| Volume Scale Input 2 | INPUT 2 | 100.0 | |
| Volume Display 2 | DISPLY 2 | 100,000 | |
| Multipoint | MULTIPT | Disable | |
| Password | | | |
| Password | PASSWORD | 00000 (unlocked) | |

Troubleshooting

Due to the many features and functions of the meter, it's possible that the setup of the meter does not agree with what an operator expects to see. If the meter is not working as expected, refer to the *Diagnostics* menu and consult the recommendations described in the following table.

Troubleshooting Tips

| Symptom | Check/Action |
|--|---|
| No display or faint display | Check input signal connections. Perform hard reset by shorting S+ and S- terminals. |
| Level display unsteady | Increase filter setting in <i>Advanced</i> menu. |
| Meter displays error message during calibration (SPN ERR) | Check signal connections. Verify minimum input span requirements. |
| Level display flashes 99999 or -9999 | Check input signal and scaling within range of 99999 & -9999 |
| Volume display flashes 9999999 or -999999 | Check level display within volume scale range of 9999999 & -999999. |
| Display response is too slow | Check filter setting to see if it can be lowered to <i>LG</i> or <i>OFF</i> . |
| If the display locks up or the meter does not respond at all | Perform hard reset by shorting S+ and S- terminals. |
| Backlight does not appear. | Backlight may not be noticeable under good lighting conditions. Check connections are as shown in <i>Figure 6</i> or <i>Figure 7</i> on page 15. |
| SafeTouch buttons do not respond | Mechanical button was pushed or SafeTouch slide switch is in lock position. The SafeTouch buttons will be re-enabled automatically 60 seconds after the last button push. If slide switch on connector board is in Lock position, switch to Unlock. Sunlight can interfere with the sensors. It is recommended to shield the window from sunlight while operating the buttons by standing so as to block direct sunlight. |
| Other symptoms not described above | Call Technical Support for assistance. |

Quick User Interface Reference

| Pushbutton | Function |
|--------------------|--|
| MENU | Go to programming mode or leave programming. Hold for 5 seconds to enter <i>Advanced Features</i> menu directly. |
| RIGHT Arrow | Move to next digit. Go to previous menu or alphanumeric character selection. Reset max or min while displayed. |
| UP Arrow | Move to next selection or increment digit. Cycle through maximum, minimum, and mA display mode. |
| ENTER | Accept selection/value and move to next selection. Acknowledge alarms. |

To enter the Advanced Features Menu, hold the **Menu** button for 5 seconds.

Max/Min Mode

While in Run Mode, pressing **Up** Arrow will initiate MAX/MIN Mode. **Up** Arrow toggles between MAX & MIN displays, and **Right** Arrow resets the MAX/MIN to the current value. Press **Menu** or wait 10 seconds to return to Run Mode. Pressing **Enter/Ack** will disable the 10 second timeout and continuously display Max or Min.

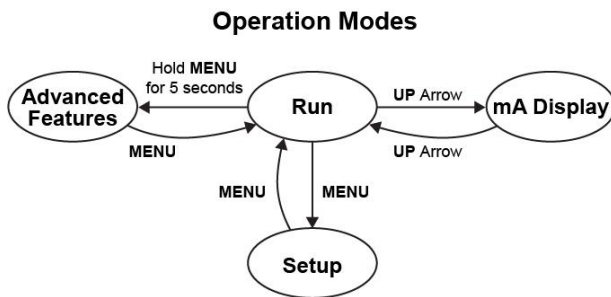

Main Menu

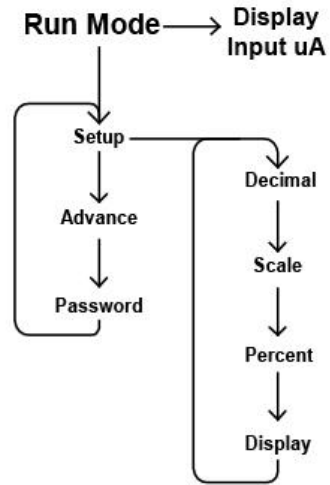

Advanced Menu

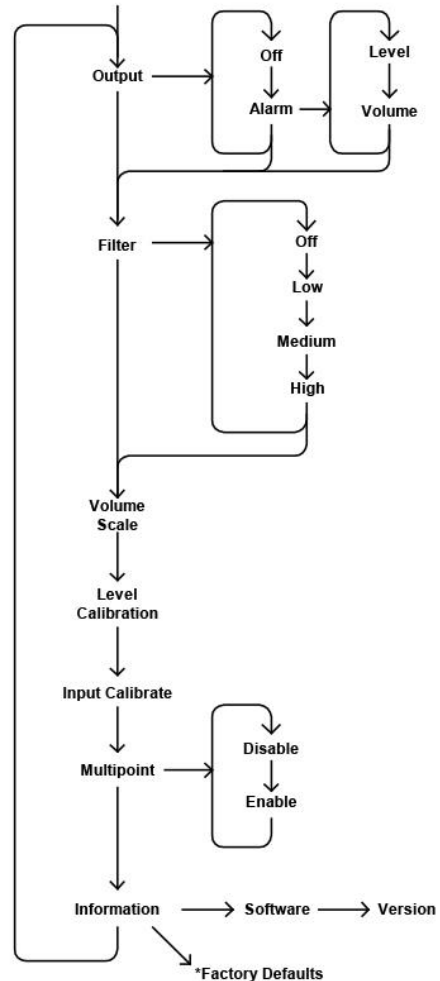

*Access by holding **Right/Reset** for 3 seconds

NOTES

Contact Precision Digital

Technical Support

Call: (800) 610-5239 or (508) 655-7300

Email: support@predig.com

Sales Support

Call: (800) 343-1001 or (508) 655-7300

Email: sales@predig.com

Place Orders

Email: orders@predig.com

For the latest version of this manual please visit

www.predig.com

PRECISION DIGITAL CORPORATION

233 South Street • Hopkinton MA 01748 USA

Tel (800) 343-1001 • (508) 655-7300

www.predig.com

