



## 440 & 450 ELECTRONIC VIBRATION SWITCHES

### Installation Manual



## 1. OVERVIEW

### 1.1 Introduction

The single setpoint models (SR) contain one trip limit for shutdown. The optional dual setpoint models (DR) contain two independent trip limits; one for alarm and one for shutdown. Shutdown and alarm limits are in engineering units of velocity. In addition, a 4-20 mA output proportional to vibration velocity is provided.

Models 440 and 450 use identical design and differ only in the enclosure. The model 440 is designed to be used in non-hazardous or non-incendive hazardous location (Class I, Division 2, Groups B, C, D, and NEMA 4X). The model 450 is designed to meet explosion-proof requirements for Class I, Division 1, Groups B, C, D installations. Unless otherwise noted, all discussions and diagrams herein assume the model 440, but apply equally to the model 450.

### 1.2 Key Capabilities

- Shutdown and alarm settings are based on vibration severity. The internal sensor (unless the external sensor option has been specified (Ordering Option I=5 – see note in Section 5.4) is a piezoelectric crystal with built in microelectronics to reduce noise sensitivity. The output signal is electronically integrated to measure and trip on velocity.
- Calibrated setpoint controls permit setpoint adjustment of vibration velocity levels up to full scale range. DR model

### Key Capabilities (continued)

switches have dual setpoints – one for alarm and one for shutdown – that are independently adjustable.

- 4-20 mA output provides a convenient interface for trending and displaying vibration amplitude in a programmable logic controller (PLC), SCADA system, data logger, or other instrumentation. 4mA corresponds to no vibration, and allows the user to distinguish between no power to the switch (0mA) and a functional switch but with no vibration present (4mA). 20mA corresponds to full scale vibration amplitude.
- Discrete outputs used for alarming and shutdown can be selected from triac, solid-state analog switch (FET), or electromechanical relays, but must be specified at time of ordering. These outputs are independently configurable for open on alarm/shutdown or close on alarm/shutdown .
- An adjustable (2-15 seconds) time delay is standard. This prevents false alarms/shutdowns on high startup vibrations and also from non repetitive transient events.
- Self-test and verification: An LED adjacent to each setpoint control illuminates the instant the measured vibration level exceeds the setpoint. The unit can be periodically verified on line by turning the setpoint control down until the LED comes on. This setting is then compared with the vibration amplitude measured via a portable vibration meter at the same location as the switch’s sensing element, providing a verification check of the unit.

 **NOTE:** Discrete outputs should be manually bypassed during this procedure, particularly if used to trip the machine. They will change state after the time delay, and should be externally jumped or otherwise disabled to prevent nuisance trips.

### 1.3 User Interface

LED illuminates immediately when vibration exceeds setpoint (but alarm or shutdown discrete outputs will change state only after time delay).

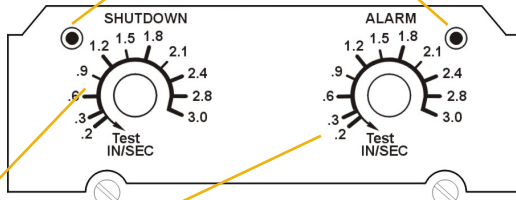

Calibrated setpoint controls enable operator to set specific velocity alarm/shutdown levels.

Adjustable time delay of 2-15 seconds.



**NOTE:** Turning either adjustment knob to the TEST position reduces the corresponding setpoint to its minimum allowable value, effectively meaning that any vibration will exceed the setpoint. Although the LED will come on immediately, the discrete output will change state only after the duration of the adjustable time delay has elapsed. If the TEST position is maintained for less than the duration of the time delay, the discrete output will not change state.

VDE approved terminal strip accepts #12 AWG wire. All hardware is captive.

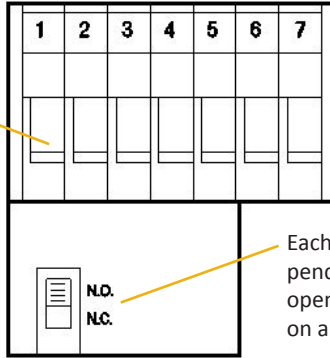

Each discrete output is independently field configurable to open on alarm (N.C.) or close on alarm (N.O.)

## 2. SPECIFICATIONS

Refer to product datasheet 1004730, available online at [www.metrixvibration.com](http://www.metrixvibration.com).

## 3. SAFETY WARNINGS



### CAUTION - SHOCK HAZARD 230/110 VOLTS

The terminal block inside the 440 is connected to AC power (110 VAC or 230 VAC depending on model) except DC input power models.

If adjustments to the device are being made with power applied, exercise caution to avoid contact with the terminal block screws by any part of the body or electrically conductive tool.

### EQUIPMENT OPERATION

Model 440 and 450 vibration switches must be installed and operated as described in this manual and in accordance with published datasheet specifications. Operation outside these limits may adversely affect the switch's alarming and shutdown capabilities, resulting in damage to machinery and property as well as jeopardizing personnel safety.

## 4. MECHANICAL INSTALLATION

### 4.1 Where to Mount the Switch

It is desirable to mount the electronic switch (or transducers for switches with external transducer option) on a bearing housing, since the forces generated by the rotating parts through unbalance, misalignment, bearing wear, etc., are transmitted to the machine's casing through the bearings.

Most bearing housings are curved so it is necessary to attach a bracket with a flat surface for mounting the switch. If the machine has bolted end plates on the bearings or horizontally split bearing housings, these bolts can be used to attach the bracket.

When bolt holes are not available or are not suitable, an alternative way is to weld an angle iron bracket similar to that in the sketch, but oriented so as to straddle the bearing housing. The best approach will typically be to mount a gusseted bracket, as shown below.

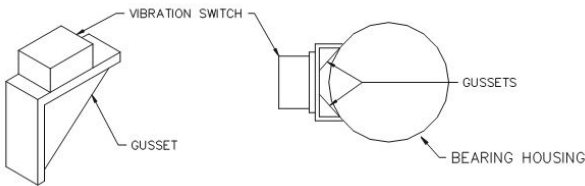

The guiding principle is to ensure that the bracket is suitably stiff such that machinery vibration is completely transmitted through the bracket to the vibration switch or sensor. Problems can occur when the bracket is too compliant, and may allow bracket resonance to amplify the actual machinery vibration, resulting in false shutdowns or alarms. For many applications, 3/8 Inch material (preferably steel) will be suitable.

### 4.2 Switch Sensitive Axis

The sensitive vibration “measuring” axis is perpendicular to the mounting base of the unit (vibration switch or transducer). Always mount the unit such that the desired vibration of the equipment being monitored will occur along this axis.



**NOTE:** Models using an external sensor will be sensitive along the sensor's axis, not the switch's axis.

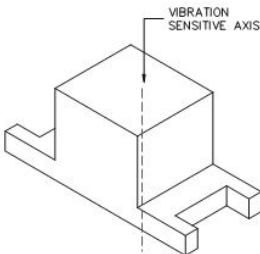

VERTICAL SWITCH ORIENTATION

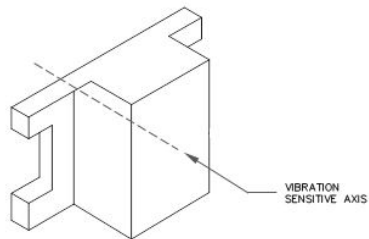

HORIZONTAL SWITCH ORIENTATION

### 4.3 Choosing Mounting Orientation

The vibration switch can be mounted in the vertical or horizontal orientation (or anything in between) without a change in its sensitivity. Ideally, the mounting orientation will be chosen by measuring the vibration levels in both directions with a vibration meter and then selecting the direction in which the highest vibration occurs. This will typically be horizontal, since most machine structures are less rigid horizontally than vertically.

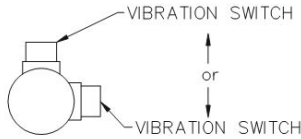

### 4.4 Number of Points per Machine

Anywhere from one to four switches are used per machine (depending on how critical the machine is to the process or how expensive it is), one on each end of the motor and one on each end of the compressor, fan, pump or whatever is being driven. If there is a gear box in between, one may be used here also.

It is quite common to use only one switch. In this case, it is best to mount on or near the driven bearing. For example, if you have a motor and large fan with a bearing on each end of the fan, the fan bearing on the motor side would be the driven bearing. It will usually see the highest forces and have the highest vibration level.

### 4.5 Mounting at other Locations

When it is not possible to mount the switch directly on the bearing housing, the switch can be located elsewhere, keeping in mind that it is usually machinery vibration that is being measured (not bracket, piping, or other vibration). Do not mount the switch in locations where very little machinery vibration is transmitted, as the switch will be less sensitive to damaging changes in machinery vibration levels. Again, it is desirable to survey the machine with a vibration meter. If the level at the intended location is not attenuated by more than about 50% relative to the levels directly on the bearing housing, it will probably be satisfactory. However, alarm and shutdown settings should then be reduced proportionately as well.

### 4.6 Mounting Surface

Choose or fabricate a solid (rigid) surface (on the equipment being monitored) to mount the vibration switch or transducer. This will ensure transfer of the vibration to the vibration transducer, while not introducing erroneous vibrations. In addition, the surface presented to the base of the unit should be flat. Fasten using sturdy hardware at all places provided.

### 4.7 Temperature Considerations

The switch is designed to dissipate internal heat by conduction through its base. Hence, it is important to keep the mounting surface below the switch max temperature limit of 140°F. If the equipment being monitored is going to exceed this limit, consideration should be given to either using one of the remote transducers, or thermally isolating the switch. To ensure accurate switch performance, a warm up time of 5 minutes is recommended.

### 4.8 Elevation Considerations

The reduced atmospheric pressure at elevations more than 2,000 meters (~6600 feet) above

sea level does not allow heat to dissipate as readily as at lower elevations, and the maximum operating temperature must be de-rated by 2% per 300 meters. Thus, a switch installed at an elevation of 2,600 meters will have a maximum operating temperature 4% lower than a switch installed between seal level and 2,000 meters. Refer to datasheet 1004730 for complete specifications.

#### 4.9 Cable/Wiring

The method chosen to electrically connect to the switch or transducer should be mechanically flexible, to eliminate the measurement of vibration of material not of interest (piping, etc.), and provide a moisture barrier as well.

Although seal tight and other flexible conduit have been used successfully, in areas of extreme humidity or moisture it is recommended that a “SO” type cable together with a suitable rain-tight CGB fitting be used.

No stress should be possible on the wiring to the terminal block. If such protection is not provided by the conduit system, some form of stress relief must be installed where the wiring exits the 440.

To reduce susceptibility to EMI/RFI, any signal-level wiring such as transducer, reset, lockout, or 4-20 mA loop should utilize shielded cable in EMI-proof conduit, separate from any power wiring. The signal-wiring conduit and power-wiring conduits can be connected at the switch entry via a “T” fitting.

#### 4.10 Sealing

In installations where temperature and humidity conditions vary around the dew point, it is important that the cover be evenly and firmly fastened down with the four screws provided (model 440) or via the threaded cover (model 450).

Although the switch enclosures meet NEMA standards for water tightness, this assumes the cover is properly seated and wiring/conduit entrances use proper seals.



**NOTE:** Unless proper drains and/or poured seals are used, conduit can allow moisture entry into the switch. Use good installation practices that slope conduit away from the switch, use drains (non-XP installations only), and make certain that cable jackets are not nicked or scuffed which might allow moisture to wick into the switch via the conductors.

## 5. ELECTRICAL INSTALLATION

### 5.1 Wiring to the Vibration Switch

See terminal numbering legends below. Refer also to the wiring diagrams of section 8.

For 440/450 Models Using Triac or Analog Switch

7	Lockout (Optional)	Not Used	8
6	Remote Reset	Not Used	9
5	Common	Input Signal (Optional)	10
4	Shutdown	Common	11
3	Circuit	4-20mA Analog Output	12
2	Input	Alarm	13
1	Power	Circuit	14

For 440/450 Models Using Mechanical Relay

7	Remote Reset	4-20mA Analog Output	8
6	Common	Not Used	9
5	Shutdown N.C.	Not Used	10
4	Shutdown Common	Input Signal (Optional)	11
3	Shutdown N.O.	Alarm N.C.	12
2	Input	Alarm Common	13
1	Power	Alarm N.O.	14



**NOTE:** DR models have both Shutdown and Alarm circuit present; SR models have only Shutdown circuit.

### 5.1.1 Input Power

Connect a grounding wire to the grounding screw provided in the switch. This is important for safety as well as noise. For AC powered units, power only with the voltage level indicated on the inner cover label. Orientation of AC power to terminals 1 and 2 is not important. For DC powered units, connect +24V to Pin 1 and Ground to Pin 2.

### 5.1.2 Shutdown Circuit

The internal shutdown switch circuit is designed to be wired in series with the external shutdown circuit i.e.; motor starter, relay, contactor, etc.

### 5.1.3 Remote Reset

Shielded wire is required. To avoid creating ground loops, the N.C. remote switch contacts should be electrically isolated from other circuits or grounds. NOTE: Remote reset is disabled if pushbutton reset option is selected.

#### Lockout (Optional)

Terminal 7 will be labeled "Lockout". Shielded wire is recommended. To avoid the possibility of ground loops, the remote N.O. lockout switch contacts should be electrically isolated from other external circuitry or grounds.

### 5.1.4 4-20 mA Analog Output

To avoid the possibility of ground loops, the 4-20 mA remote meter terminals should be electrically isolated from external grounds. Shielded wire is recommended to protect against damage due to long wire runs and the possibility of high induced voltage spikes from storms, etc. The 4-20 mA output is self powered and therefore requires no external power source.

### 5.1.5 Alarm Circuits

The internal single pole solid state switch between terminals 13 and 14 is designed to be wired in series with the external alarm circuit i.e.; annunciator, lamp, relay, etc.

## 5.2 Functional Description and Installation Considerations

### 5.2.1 Alarm or Shutdown

### 5.2.2 Units with Triac Outputs (ordering options D and/or E = 1)

The triacs used in model 440/450 vibration switches carry medium power ratings and are useful in controlling relays, contactors, and most motor starters directly. Maximum noise immunity is obtained when used in the open on alarm (N.C.) mode. Consult Metrix product datasheet 1004730 for comprehensive specifications pertaining to triac outputs.

### 5.2.3 Units with Analog Switch (FET) Outputs (ordering options D and/or E = 2)

For light loads such as computers or PLCs, the analog switch output is easier to interface since it has virtually no leakage current. The analog switch does not require the 50 mA holding current of a triac and operates equally well with AC or DC. Consult Metrix product datasheet 1004730 for comprehensive specifications pertaining to FET outputs.

#### 5.2.4 Units with Electromechanical Relay Outputs (ordering options D and/or E = 4)

Electromechanical relays are also available and represent the most flexible type of output. They are a good choice for a variety of applications. Consult Metrix product datasheet 1004730 for comprehensive specifications pertaining to relay outputs.

#### 5.2.5 Open/Close on Alarm

The alarm and shutdown triacs (or analog switches) are independently field settable for N.O. (close on alarm) or N.C. (open on alarm). The switches are accessible with a non-conductive screwdriver via the inner side panels. Open on alarm is recommended in installations where triac lines are likely to be noisy, i.e.: large transient voltage spikes due to unsuppressed relay, solenoid or other inductive loads.

#### 5.2.6 Auto Reset Mode

In this mode, alarm and shutdown switches are automatically reset to the non-alarm/non-shutdown condition when the vibration level falls below the set point.

#### 5.2.7 Latch Mode

In this mode, alarm and shutdown switches remain “latched” in alarm (shutdown) condition when the vibration level exceeds the set point for the duration of the time delay. The unit is in this condition when the reset terminal is connected to common.

#### Remote Reset Mode

When wired in this mode, the alarm and shutdown switches latch in “trip”, but can be reset to the “non-alarm/non-shutdown” mode by momentarily interrupting the connection from terminal Reset to Common. This can be accomplished with a normally closed momentary switch. The switch contacts should be isolated from other circuits, potentials or grounds.



**NOTE:** Remote reset is disabled if pushbutton reset option is selected.

#### 5.2.8 Optional Power-Up Timed Inhibit (20-Second Lockout optional)

This 20-second Power-Up timed inhibit (Lockout) feature is an option which inhibits the trips from actuating. The trips will not be permitted to actuate for as long as the Lockout terminal is connected to common. Trips will be allowed to trip after 20 seconds from when the Lockout is disconnected/open from the common.

#### 5.2.9 4-20 mA Output

This loop supplies its own 24Vdc power and provides a 4-20 mA output current proportional to vibration.

Most switches are supplied with ordering option B=2 (absolute 4-20mA output reference) where 4mA = no vibration and 20mA = full scale vibration (refer to product datasheet 1004730 for full scale range options). A small number of older switches may use a B option other than 2, designating an analog output that is proportional to the setpoint rather than the full-scale range. Consult the factory for additional information.



**NOTE:** Do NOT connect the 4-20mA output to an external source of loop power as this may damage the switch.



### 5.3 Special Considerations

#### 5.3.1 Light Loads

The solid state triacs used in the standard 440 series are a special high transient immunity, medium power type. Off state leakage is 1 mA max and should not create any problems, even when interfaced with a load as light as a programmable controller.

Minimum load required to keep the triac on is 20 mA typical and 50 mA max due to the “holding current” specifications. If the load is less than this, a resistor may have to be placed in parallel with the load, i.e.; for 115 VAC light load (50 mA or less) a 2K-ohm 10 watt power resistor is recommended.

#### 5.3.2 D.C. Loads with triacs

Although most applications use AC input power and AC on the triac outputs (alarm and shutdown), these triacs may be used in DC applications providing minimum loading requirements are met. When DC is used, a triac will automatically latch in the “on” condition after trip, thus only “close on alarm” (N.O.) can be used. To reset an external reset switch, the rest switch must be wired in series with the load. To avoid large voltage drops during DC operation, the triac should be connected as follows:

Shutdown:	Term 4 POS	Alarm:	Term 14 POS
	Term 3 NEG		Term 13 NEG

#### 5.3.3 170 mA Analog Switch Option

The special conditions of sections 5.3.1 and 5.3.2 do not apply. However, maximum current is limited to 170 mA.

### 5.4 Functional Circuit Block Description

An internal transducer module consisting of a crystal assembly and integral charge amplifier senses vibration. Thus, the electrical output of the transducer is a well-buffered (low impedance) signal directly proportional to vibratory acceleration levels (g) at the switch.



**NOTE:** Models using an external (Ordering Option I=5) sensor do not have an internal accelerometer and will measure vibration at the sensor location, not the switch location. Refer to Metrix product datasheet 1004730 for a list of ordering options characterizing external transducers.

The raw acceleration signal goes to a custom hybrid circuit that integrates the signal and provides an AC signal proportional to vibratory velocity instead of acceleration. This signal is then routed through an amplifier, the gain of which is controlled by the shutdown setpoint.

Next, the signal is processed through a true RMS-to-DC stage and compared against a preset internal voltage reference. If the signal level is higher than reference, the shutdown LED is illuminated.

If the voltage level stays above the reference for the duration of the time delay, an output trip occurs and the shutdown solid-state relay will trip.

Alarm trip is derived in much the same manner, branching from the output of the RMS-to-

DC stage. Likewise, the DC output is directed to the voltage-to-current hybrid.

## 6. CONTROL SETTINGS

### 6.1 Setting Trip Points

The Model 440DR provides two setpoints: one for alarm and one for shutdown.



**NOTE:** SR models provide only one setpoint (shutdown).

The first alarm is normally set at a vibration alarm level to provide early warning that the condition of the machine is deteriorating. If the machine condition continues to deteriorate, the shutdown setpoint provides protection against catastrophic failure. The shutdown and alarm setpoints are set directly in inches/seconds or mm/sec.

The Warning Level Guide below indicates recommended starting points for vibration warning levels, defined as levels at which abnormal wear is occurring. Vibration analysis by competent machinery diagnostic personnel is recommended when a warning alarm level has been reached. Different warning levels are given for different types of machinery.



**NOTE:** The ranges below are typical. Each machine will have its own acceptable levels of vibration, depending on how it is loaded, the particular installation, and the tolerances of the machine itself. The chart below is a guideline and does not relieve the user of responsibility for determining their own acceptable alarm and shutdown levels for the equipment at hand.

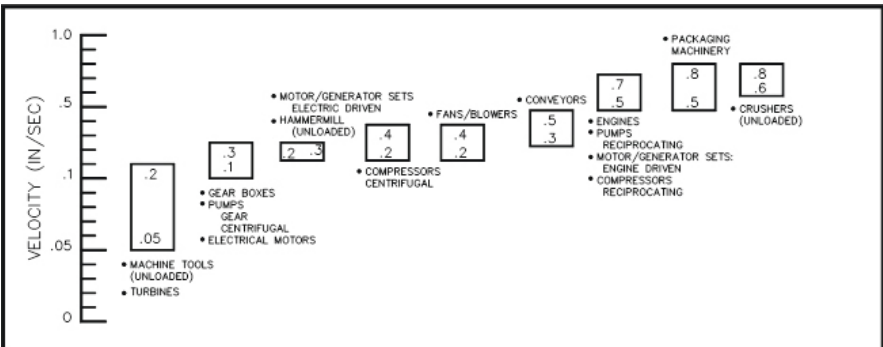

Warning Level Guide

### 6.2 Setting of Time Delay

An important feature of Model 440/450 switches is the built-in time delay. This prevents triggering of the alarm or shutdown functions from transient increases in vibration levels. It also avoids shutdown due to transitory vibrations occurring during start-up.

The time delay is adjustable. The factory default setting is three (3) seconds unless specified otherwise.

The time that the vibration amplitude must persist above a setpoint before the discrete output changes state is individually adjustable for shutdown and alarm from 2 to 15 seconds.

To readjust the time delay, turn the shutdown setpoint (or alarm setpoint for alarm time delay) knob CCW until the LED illuminates. The time from this point to relay actuation is the time delay. Change the time delay via a nylon non-conductive screwdriver. Set CW to increase time delay (one complete turn is approximately 0.5 seconds). Then, recheck and readjust until the desired time delay is achieved.

### 6.3 Test Mode

The TEST position of both shutdown and alarm setpoint adjustment knobs is used to test the switch functions without the need for vibration. When the shutdown knob is turned to TEST, the shutdown LED should illuminate and the discrete output should change state after the delay time (see section 6.2) has elapsed. The alarm TEST position (available only on DR model switches) functions in similar fashion, but has no effect on the 4-20 mA output.



**NOTE:** If the shutdown or alarm knob is moved to the TEST position but then returned to a normal setting before the duration of the time delay has elapsed, the LED will come on but the discrete output (triac, FET, or relay) will not change state.

### 6.4 Ascertaining Current Vibration Levels

When the 4-20mA output is not being used with a strip chart recorder, PLC, or other logging device, you can place an ammeter across this output and the current measured. 4mA corresponds to zero vibration and 20mA corresponds to full scale vibration. Readings in between these two extremes can be ascertained by scaling proportionately from 0% (4mA) to 100% (20mA). Alternatively, the LED indicators for alarm (DR model only) or shutdown (both SR and DR models) can be used. Since these LEDs activate instantaneously (i.e., before the adjustable time delay of section 6.2), they can be used in a momentary fashion to check the machine's actual vibration level. Slowly decrease the setpoint by turning the setpoint adjustment knob counter-clockwise until the corresponding LED illuminates. Note this setting and quickly return the knob to its original setting (before time delay runs out). The level at which the LED illuminates corresponds to the actual vibration level.



**NOTE:** For DR model switches where both shutdown and alarm setpoints will be available, it is recommended that the alarm setpoint adjustment be used for this procedure instead of the shutdown setpoint, to prevent an inadvertent machine trip.

# 7. OUTLINE & DIMENSIONS

## 440 Model

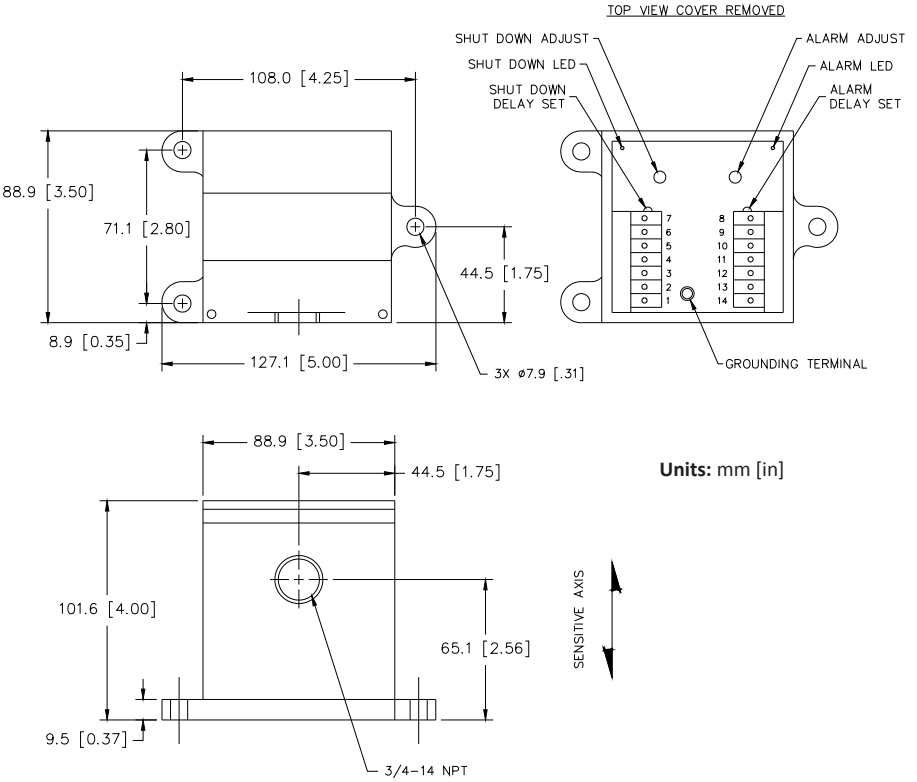

# 450 Model

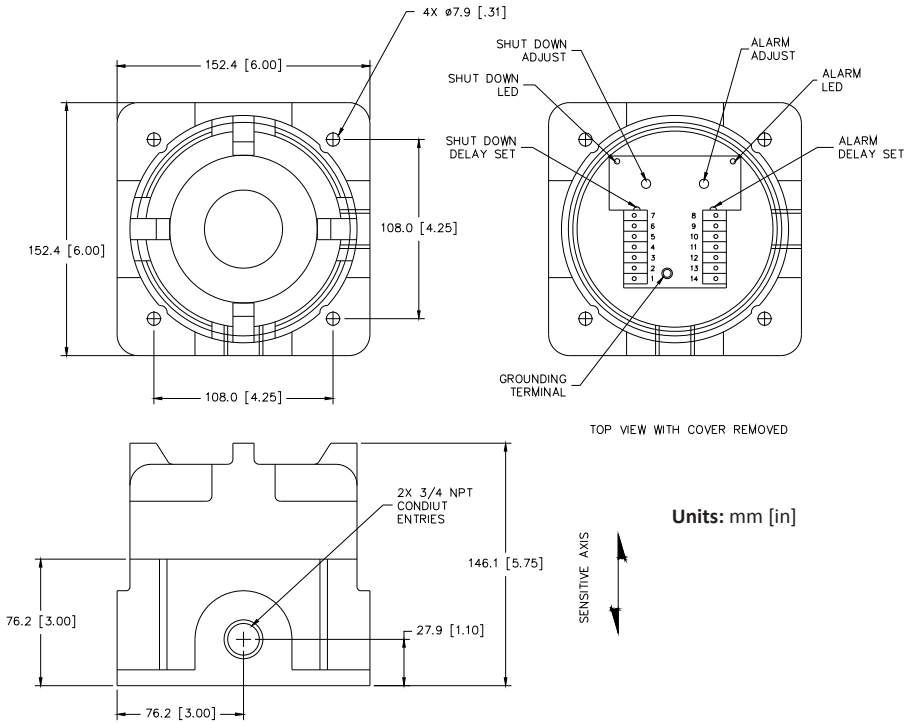

## 8. WIRING DIAGRAMS

These diagrams depict connections for models with all options present. Not all connections may be available on your specific switch(es), depending on whether optional features were specified at time of ordering.

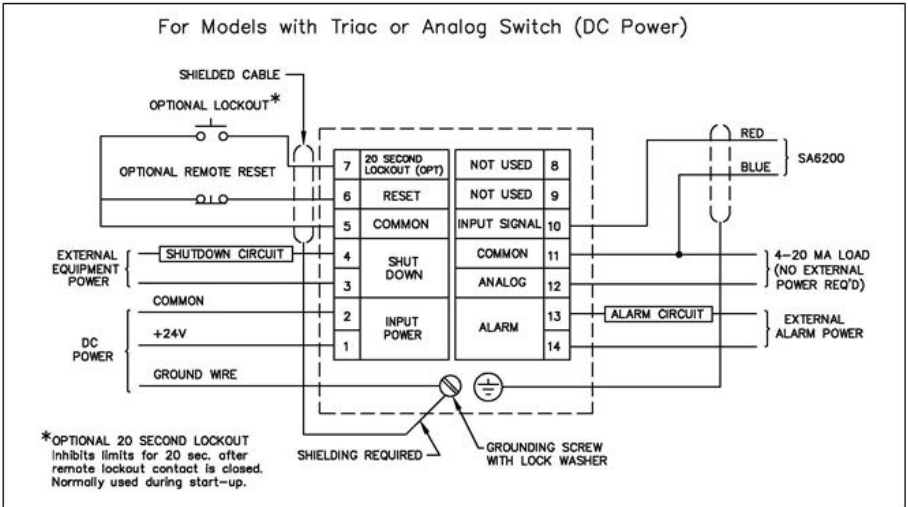
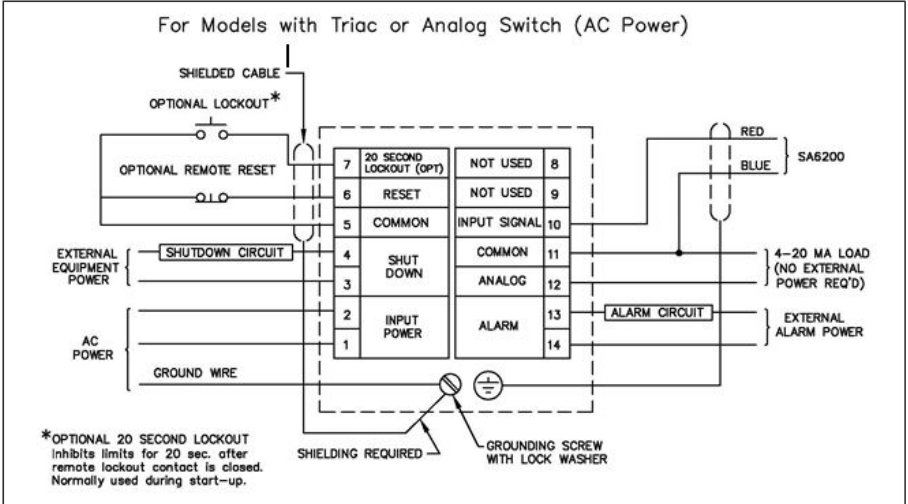

For Models with Mechanical Relay (AC Power)

Note: Alarm terminals are used only for DR Models.

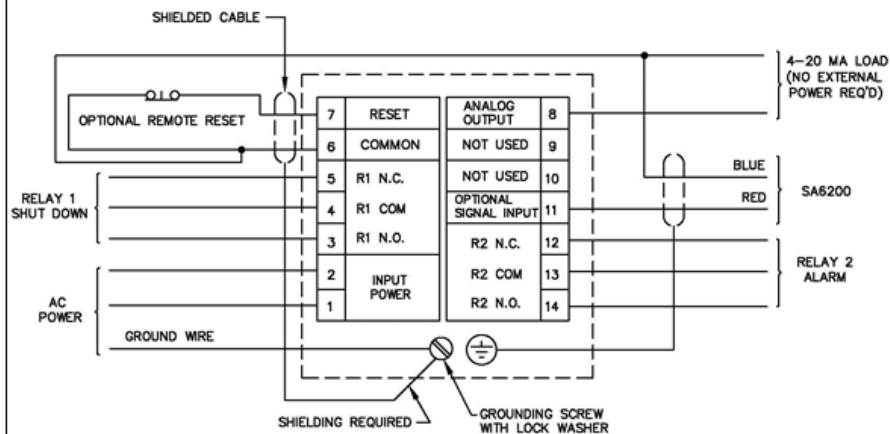

For Models with Mechanical Relay (DC Power)

Note: Alarm terminals are used only for DR Models.

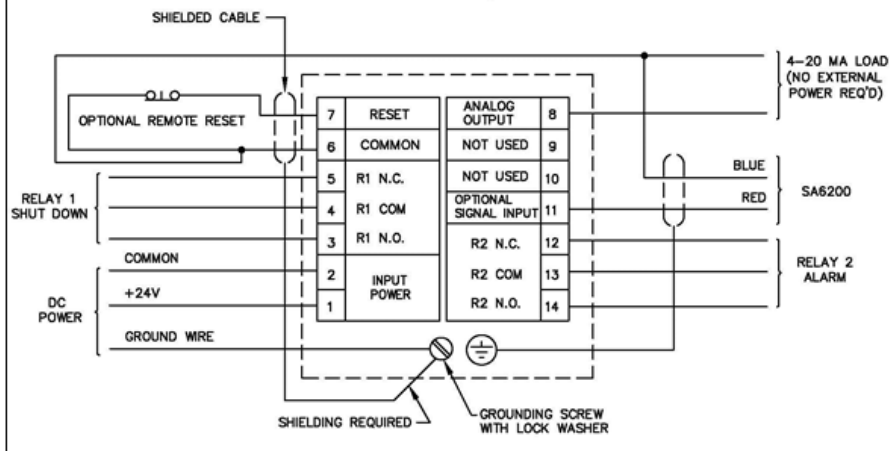

## **ENVIRONMENTAL INFORMATION**



This electronic equipment was manufactured according to high quality standards to ensure safe and reliable operation when used as intended. Due to its nature, this equipment may contain small quantities of substances known to be hazardous to the environment or to human health if released into the environment. For this reason, Waste Electrical and Electronic Equipment (commonly known as WEEE) should never be disposed of in the public waste stream. The “Crossed-Out Waste Bin” label affixed to this product is a reminder to dispose of this product in accordance with local WEEE regulations. If you have questions about the disposal process, please contact Metrix Customer Services.

[info@metrixvibration.com](mailto:info@metrixvibration.com)

[www.metrixvibration.com](http://www.metrixvibration.com)

8824 Fallbrook Dr. Houston, TX 77064, USA

Tel: 1.281.940.1802 • Fax: 1.713.559.9421

After Hours (CST) Technical Assistance: 1.713.452.9703